



## CABINETY DESIGN PLANNER

Use this form to gather details for your next project.

Please fill out one form per room.

Send completed form to \_\_\_\_\_ or fax to \_\_\_\_\_.

DATE

PROJECT NAME

### HOMEOWNER INFORMATION

Name \_\_\_\_\_

Phone \_\_\_\_\_

Email \_\_\_\_\_

### CONTACT INFO

Account Number \_\_\_\_\_

Designer Name \_\_\_\_\_

Fax Number \_\_\_\_\_

Phone \_\_\_\_\_ Ext \_\_\_\_\_

Email \_\_\_\_\_

### TYPE OF PROJECT

- New Construction
- Remodel

### INSTALLATION

Who will be installing your cabinets?

- Professional Installer/ Contractor
- Do-It-Yourself

### BUDGET

Please select the most realistic budget for cabinetry only.

- Under \$5,000
- \$5,000-\$10,000
- \$10,000-\$15,000
- \$15,000-\$20,000
- \$20,000-\$25,000
- \$25,000-\$30,000
- \$30,000-\$35,000
- Over \$35,000

### PRIMARY CABINETY

Room \_\_\_\_\_

Door Style \_\_\_\_\_

Wood Type \_\_\_\_\_

Color \_\_\_\_\_

Drawer Header  Slab  5-Piece  
 Combination Slab/ 5-Piece

*(Available on Select Door Styles)*

Drawer Box  Wood Box  Double Steel Wall

Interior  White  
 Natural  
 Plywood

### ADDITIONAL CABINETY

Room \_\_\_\_\_

Door Style \_\_\_\_\_

Wood Type \_\_\_\_\_

Color \_\_\_\_\_

Drawer Header  Slab  5-Piece  
 Combination Slab/ 5-Piece

*(Available on Select Door Styles)*

Drawer Box  Wood Box  Double Steel Wall

Interior  White  
 Natural  
 Plywood

# DESIGN WISH LIST



## BASE OPTIONS

- Roll Out Trays
- Blind Corner Cabinet
- Drawers (3 or 4)
- Mixer Shelf
- Tray Dividers
- Pantry Cabinet
- Drawer Insert
- Sink Door Trays
- Sink Pull Out Storage
- Cutting Board Insert
- Can Good Storage
- Lazy Susan
- Microwave Cabinet
- Pot/ Pan Drawers (2 or 3)
- Trash/ Recycle
- Pull Out Cabinets
- Cutlery Insert
- Sink Tilt Out Tray
- Sink Towel Bar
- Bread Board
- Wicker Baskets
- Other: \_\_\_\_\_

## WALL OPTIONS

- 24" Deep Refrigerator Cabinet
- Diagonal Corner
- Wall with Drawers
- Spice Rack on Door
- Microwave Cabinet
- Open Bookshelf
- Wood Hood
- Stemware Holder
- Spice Pull Outs
- Appliance Garage
- Plate Rack
- Stacked Cabinets
- Other: \_\_\_\_\_

## TALL OPTIONS

- Roll Out Trays
- Pull Out Pantry
- Swing Out Pantry
- Adjustable Shelves
- Tray Storage
- Can Good Storage
- Other: \_\_\_\_\_

## VANITY OPTIONS

- Mirror
- Linen Cabinet
- Furniture-like Piece
- Vanity Pull Out
- Matching Ends
- Vanity Hampers
- Medicine Cabinet
- Tilt Out Trays
- Other: \_\_\_\_\_

## OFFICE/ OTHER OPTIONS

- File Drawers
- Wood Top
- Base Open Shelf
- Wall Open Shelf
- Tall Open Shelf
- Desk Drawer
- Floating Shelf
- Wainscot Panels
- Other: \_\_\_\_\_

## DOOR OPTIONS

- Prep Doors for Glass
- Glass Insert
- Mullion/ Grille Doors
- Other: \_\_\_\_\_

## NOTES

---



---



---



---



---



---

# APPLIANCE SPECIFICATIONS



APPLIANCE	BRAND	MODEL	APPLIANCE DIMENSIONS (Width x Height x Depth)	CUTOUT DIMENSIONS (Width x Height x Depth)	PANEL DIMENSIONS (Width x Height x Depth)
Refrigerator with Panel <input type="checkbox"/> Yes <input type="checkbox"/> No					
Range					
Range Hood					
Cook Top					
Downdraft Ventilator					
Single Oven					
Double Oven					
Microwave					
Over the Range Microwave					
Dishwasher with Panel <input type="checkbox"/> Yes <input type="checkbox"/> No					
Sink <input type="checkbox"/> Under-mount Farm <input type="checkbox"/> Single <input type="checkbox"/> Double					
Prep Sink Location					
Compactor with Panel <input type="checkbox"/> Yes <input type="checkbox"/> No					
Wine/ Beverage Cooler with Panel <input type="checkbox"/> Yes <input type="checkbox"/> No					
Warming Drawer with Panel <input type="checkbox"/> Yes <input type="checkbox"/> No					
Ice Maker with Panel <input type="checkbox"/> Yes <input type="checkbox"/> No					
Washer					
Dryer					
Television					
Other					
Other					
Other					

# FLOOR PLAN

## FLOOR PLAN INFORMATION

- Begin by drawing the shape of your room. Add doors, windows, breaks in the wall, and all obstructions. Indicate in which direction doors swing and where they lead.
- Measure all around the room until everything is located, measured, and marked on your sketch.
- Indicate the overall length and height of walls. For new construction, remember to account for sheetrock thickness.
- Check that you correctly measured your room by adding your measurements for each wall and comparing them to the opposite wall.
- Include dimensions of islands or peninsulas.

**IMPORTANT: WE STRONGLY RECOMMEND A PROFESSIONAL INSTALLER OR CONTRACTOR DOES THE FINAL MEASUREMENTS.**

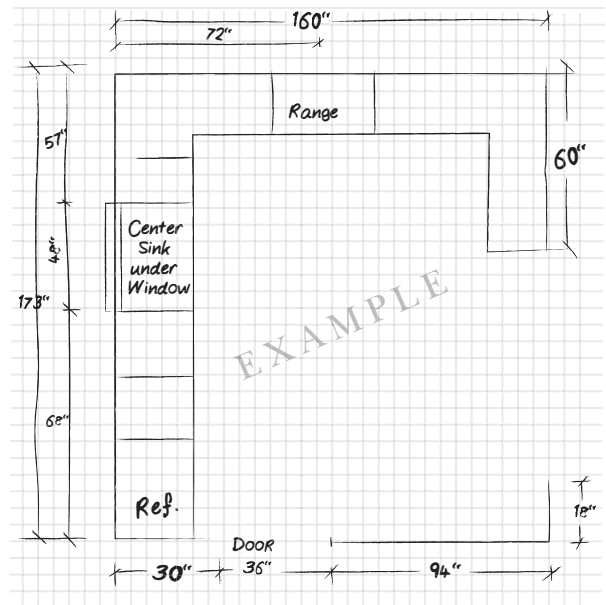

## WINDOW AND DOOR DIMENSIONS

Measure the dimensions of all the windows and doors in the room. For door measurements use a for door width and b for door height. Also, make note of the door hinge and swing.

Window and door measurements a and b should include trim.

Use the number designation from the grid (1,2,3, etc.) to label the location of the windows and doors on your final floor plan.

Please record all dimensions in inches.

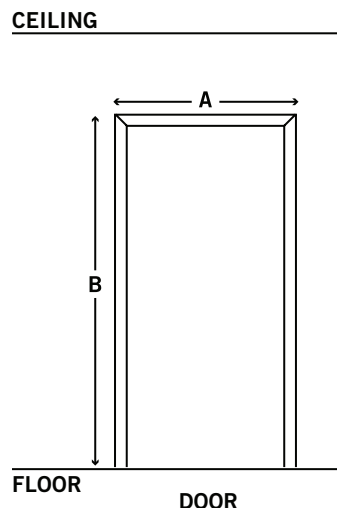
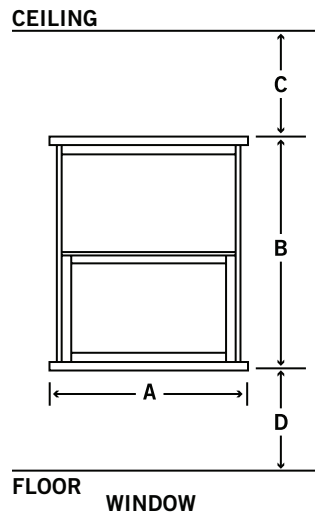

## WINDOWS

	A	B	C	D
1				
2				
3				
4				

## DOORS

	A	B	HINGE (left/right)	SWING (in/out)
1				
2				
3				
4				

# FLOOR PLAN

**RECOMMENDED SCALE: 1/2 INCH = 1 FOOT** **NOTE: PLEASE INCLUDE THE FOLLOWING ON THE FLOOR PLAN DRAWING:** 1. Dimensional floor plan with all openings (doors & windows) 2. Ceiling height 3. Any unusual architectural details in the room.

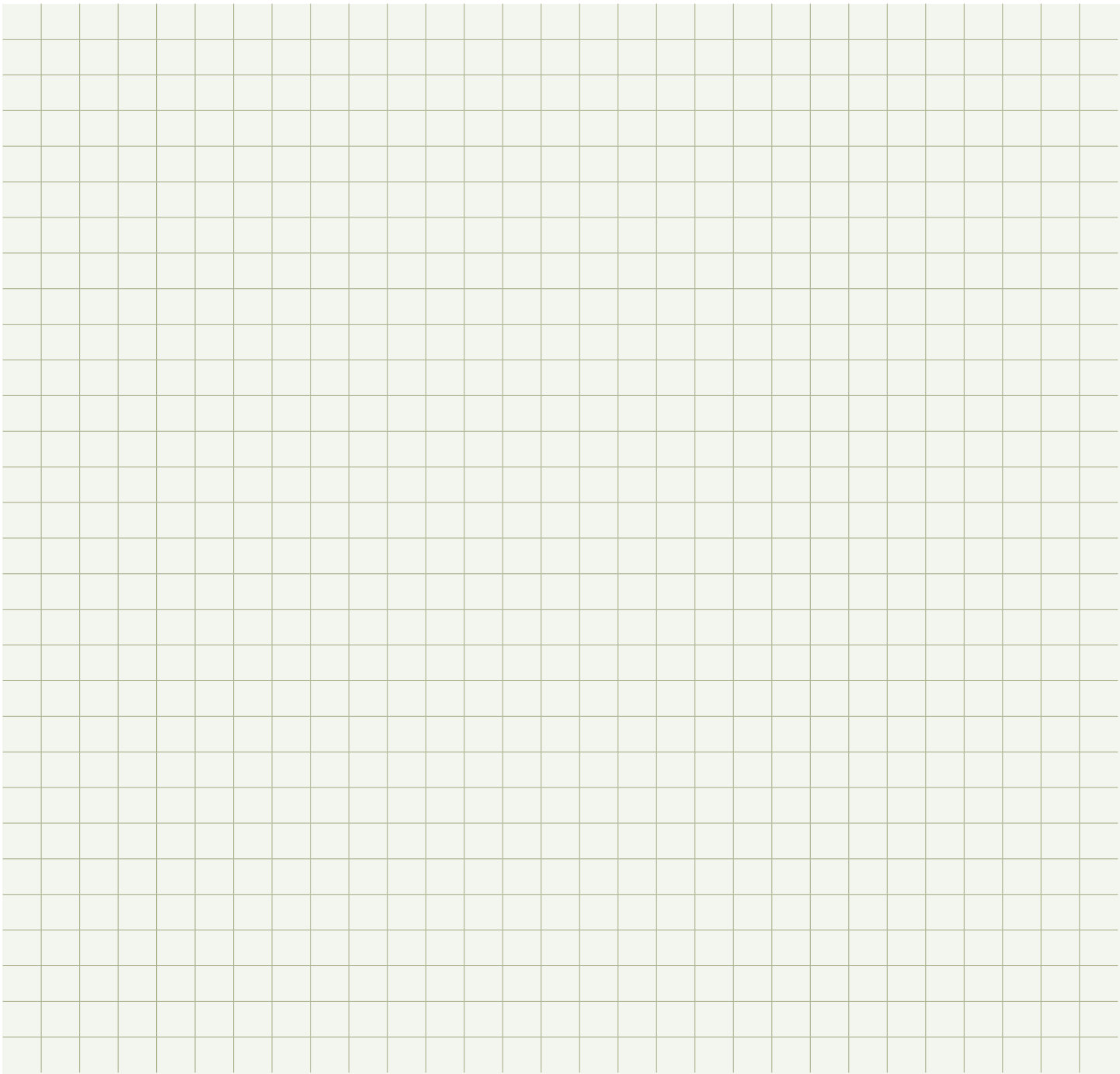

## ROOM INFORMATION

Measure the dimensions requested below for the cabinetry as it exists in the room today. (See diagram at right)

**Record measurements in inches, on the lines indicated below:**

A: Finished Floor to Ceiling Height \_\_\_\_\_

B: Finished Floor to Top of Wall Cabinet \_\_\_\_\_

C: Soffit/ Open Area Height \_\_\_\_\_

D: Wall Cabinet Height \_\_\_\_\_

### Bathroom Information

A: Finished Floor to Ceiling Height \_\_\_\_\_

E: Vanity Height \_\_\_\_\_

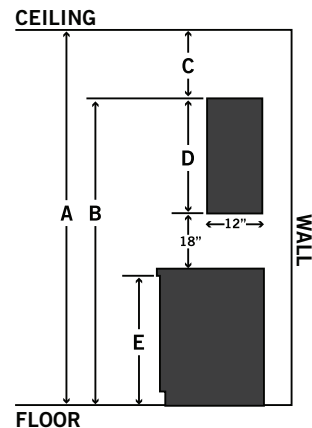

**CABINETRY SHOWROOM LOCATIONS**

**EMERSON, NJ**  
(201) 705-5804

**WANTAGE, NJ**  
(973) 875-5106

**SUCCASUNNA, NJ**  
(973) 584-2444

**WARWICK, NY**  
(845) 986-2255