



Boise Cascade
Engineered Wood Products

EASTERN ENGINEERED WOOD PRODUCTS **VERSA-STUD® 1.7 2650** **WALL GUIDE**

*Stronger
and
Stiffer
for
Tall Walls
and
High Wind
Loads*

*Straighter
for
Cabinet
and
Tile Walls*

Better homes from better builders —
by design . . .
with **VERSA-STUD®** wall framing

VERSA-STUD 1.7 2650
WALL GUIDE EAST
11/07/2008

VERSA-STUD® 1.7 2650

Engineered Studs for Tall Walls

VERSA-STUD® 1.7 2650 laminated veneer lumber wall framing is engineered for the high quality builder who wants . . .

- Stronger walls to resist wind loads
- Stiffer walls for a solid feel
- Straight walls for a high quality finish



Long, continuous **VERSA-STUD® 1.7 2650** wall framing will provide superior strength, stiffness, and appearance in any tall wall application. **VERSA-STUD® 1.7 2650** wall framing provides more resistance to wind pressure than walls framed with dimension lumber and eliminates the hinge created by platform framing. 1 1/2" x 5 1/2" **VERSA-STUD® 1.7 2650** wall framing has 2.3 times more bending strength than No. 2 SPF 2x6 studs.

Building Code Approved
for Both Prescriptive and
Engineered Wall Stud Design

* 9 1/4" and 11 1/4" depths may be available. Check with supplier or Boise EWP representative for availability.

Table of Contents

Product profile	2	VERSA-STUD® & VERSA-LAM® Column Details	12
Prescriptive Design	3	VERSA-LAM® 1.7 2650 Exterior Wall Column Table	13
Engineered Design Assumptions for Load Tables	4	Connectors	14
Wall Deflection	5	Connectors / Allowable Holes and Notches	15
Determining Wind Load	6	Design Properties	16
Wind Load Definitions	7	VERSA-STUD® Wall Sheathing Nailing	17
VERSA-STUD® & VERSA-LAM® Column Design Example	8	BC COLUMN™ Software	18
Stud Load Tables - VERSA-STUD® 1.7 2650 1 1/2" x 3 1/2"	9	Computer Software	19
Stud Load Tables - VERSA-STUD® 1.7 2650 1 1/2" x 5 1/2"	10	Information and Support, SFI, Lifetime Guarantee	Back cover
Stud Load Tables - VERSA-STUD® 1.7 2650 1 1/2" x 7 1/4"	11		

VERSA-STUD® may be used as wall studs in accordance with the prescriptive requirements in section 2308.9 of the IBC and section R602 of the IRC. The below table lists span and spacing limits for prescriptive stud design. Prescriptive design is valid for structures where the wind load does not exceed 110 mph (100 mph in hurricane-

prone regions), the ground snow load does not exceed 70 psf, dead loads on floors or roof do not exceed 20 psf, and several other provisions listed in both building codes. The building design professional of record shall determine whether the structure qualifies for prescriptive design.

Prescriptive Wall Stud Limits for Conventional Construction

Wall Type	Stud Size	Stud Height	Max O.C. Spacing
Bearing wall supporting roof and ceiling only	1½" x 3½"	10'	24"
	1½" x 5½"	10'	24"
Bearing wall supporting one floor only	1½" x 3½"	10'	24"
	1½" x 5½"	10'	24"
Bearing wall supporting one floor, roof and ceiling	1½" x 3½"	10'	16"
	1½" x 5½"	10'	24"
Bearing wall supporting two floors, roof and ceiling	1½" x 3½"	10'	—
	1½" x 5½"	10'	16"
Non-bearing walls	1½" x 3½"	14'	24"
	1½" x 5½"	20'	24"



• Limits per IRC Table R602.3(5)

Using VERSA-STUD® for Cabinet and Tile Walls

Dimension lumber can exceed 30% moisture content. Wood dries to a moisture content of 10-12% once the building is finished. Shrinkage and warping of 2x studs is a problem in walls where cabinets are hung or tile is installed. Though 2x studs cost less, added labor from shimming cabinets, straightening walls and drywall repairs can quickly add up. VERSA-STUDS® eliminate these issues, providing a straight and true wall every time.

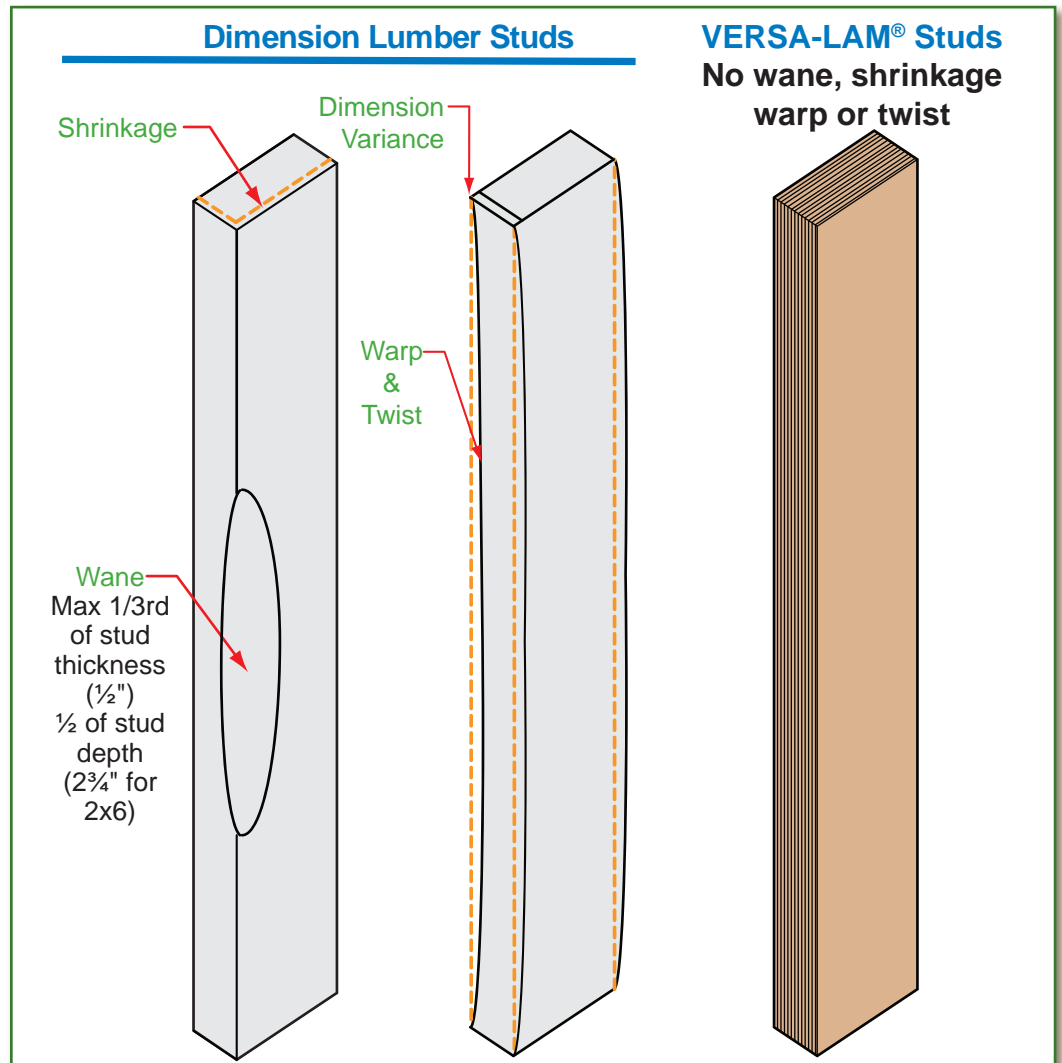

Load table values are based upon axial loads applied at the top of the stud and lateral wind loads perpendicular to the wall (out of plane loading). Lateral loads parallel to the wall (in-plane loading), caused by seismic and wind, shall be designed by the project's design professional of record.

Allowable loads based upon the design provisions of the National Design Specification for Wood Construction (NDS), 2005 edition.

Studs receive axial load concentrically through a double top plate and thus no eccentricity is assumed.

A buckling length coefficient K_e (based on the fixity of stud ends) is 1.0.

Load table values based upon assumption that stud walls have structural sheathing applied to one side or a combination of non-structural sheathing on the exterior side and gypsum wallboard on the interior side.

Blocking between studs required at a maximum spacing of 8'-0".

The repetitive member factor of 1.04 has been applied to the VERSA-STUD® allowable bending stress.

Wind load duration factor $C_D = 1.6$.

Maximum rough opening height of adjoining openings shall not exceed 84".

Double stud members and larger members shown in tables are assumed to be located between openings or at sides of openings. Single stud members shown in tables shall not be used between openings.



Load Combinations

The allowable design loads shown in this guide are based upon load combination equations for allowable stress design (IBC 06 Section 1605.3.1). Specifically for wall applications:

1. roof dead load + roof live or snow load
2. roof dead load + 0.75 x (roof live or snow load + wind load)
3. 0.6 x dead load + wind load

Since the chances are extremely remote that the maximum roof live or snow load will be present at the same time as a maximum wind load, the IBC allows for a 25% reduction in both loads when applied simultaneously in load combination #2.

Code References

When calculating deflection from wind, the design wind load is determined by multiplying the Components & Cladding pressure by 0.7 (IBC 06 Table 1604.3, footnote f & IRC 06 Table R301.7, footnote a).



Deflection of individual wall studs is calculated similar to that of joists and beams. The stud height, on-center spacing and stiffness determine the deflection from a design wind load. Below are the building code deflection limit provisions dependent upon the wall coverings.

Wall Type or Component	Max Deflection Limit	Corresponding Max Deflection for 20' wall height	Code Reference
Exterior Walls with plaster or stucco finish	L/360	0.67 in	IRC 06: Table R301.7
Exterior walls with brittle finishes (brick and stone veneer - see note below)	L/240	1.0 in	IBC 06: Table 1604.3 IRC 06: Table R301.7
Interior walls and partitions	L/180	1.33 in	IRC 06: Table R301.7
Mullions (members supporting windows or doors)	L/175	—	IRC 06: R613.9.3
Exterior walls with flexible finishes (lap, panel and metal sidings)	L/120	2.0 in	IBC 06: Table 1604.3 IRC 06: Table R301.7

Wall stud deflection may occur both into the structure (positive pressure) or out from the structure (negative pressure). Thus, the total amount of possible movement is actually almost twice the deflection value shown in the design tables (see detail below). As shown in the table above, using the code minimum L/120 limit for 20' stud height can result in a deflection of 2 inches. More restrictive deflection limits may be used, similar to Boise Cascade's Three and Four Star Floor Performance tables for BCI® Joists. The allowable load tables on pages 9-11 provide maximum loads for deflection limits ranging from L/360 to L/120. For applications where a tighter deflection limit is needed, the stud may be designed using the BC COLUMN™ software. As is the case with floors, the deflection of tall walls should be considered in the design phase of the project.

Deflection criteria is used to limit serviceability issues such as doors and windows binding, cracking of exterior and interior surface materials, perceived sounds due to wall movement, glass breaking, wall vibration and movement when pushed on. Wind produces pressure and suction loads on a wall producing deflection inward and outward. Vibration of walls can occur with high span/depth ratios much like a floor joist where depth equals the wall thickness. For further information on wall vibration, please contact Boise EWP Engineering.

In regards to brick veneer, though the IBC and IRC list a deflection limit of L/240, the Brick Industry Association (BIA) recommends designing studs to a deflection limit of L/600 to limit cracking of the veneer caused by excessive deflection. Such designs may be analyzed using BC COLUMN™ software.

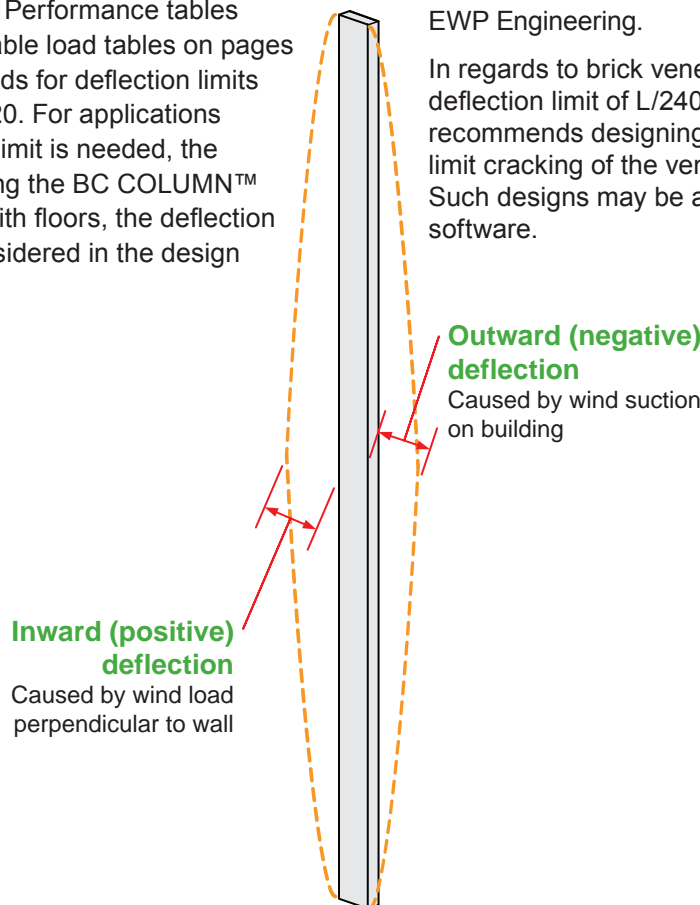

In some areas the design wind load, in units of psf [lb/ft²], is provided for residential construction by the local building code jurisdiction. For example, the State of Wisconsin Uniform Dwelling Code mandates a 20 psf design wind load. *Please refer to the local building code department for such information.*

For areas that do not provide a wind load or for non-residential projects, the wind load may be determined by using the basic wind speed, in units of mph or miles per hour. The wind speed is then converted into a design wind load by calculating all the necessary factors required by ASCE 7, per the IRC and IBC codes. These factors are dependent on the site location of the project and the dimensions of the structure. Typically, the project's design professional of record performs this analysis. The following is an overview of this procedure:

- Determine basic wind speed:** Contour maps are provided in the IRC & IBC. The majority of the inland U.S. has a wind speed of 90 mph. However, basic wind speeds up to 150 mph are required in coastal areas. In addition, special wind region areas exist where the wind speed is higher. Consult with the local building code jurisdiction for the site's design wind speed.
 - Determine the project's exposure category:** The exposure of the site will affect the wind load; wind pressure will be less within a subdivision versus a structure near a body of water. For wood-frame buildings, the three exposure categories are defined
- (see IRC 301.2.1.4 for complete definitions):
- Exposure B: Urban and suburban (subdivision) areas, forest land.
 - Exposure C: Open terrain with scattered obstructions less than 30 feet tall extending more than 1500 feet from the site in any direction.
 - Exposure D: Flat, unobstructed areas exposed to wind over open water (excluding shorelines in hurricane prone regions) for a distance of at least 1 mile.
- Determine the stud or column's effective wind area:** Calculated using the greater of $L^2/3$ or the tributary area, see Effective Wind Area in Wind Load Definitions, page 7.
 - Determine remaining factors:**
 - Importance Factor: 1.0 for most structures, 1.15 for essential service buildings.
 - Topographical Factor: 1.0 for most structures, higher for buildings on hills or ridges.
 - Determine mean roof height:** The distance between grade and a midpoint height between the eave and ridge.
 - Go to the tables in ASCE 7 to determine the design wind load.** For a mean roof height of 33', importance factor = 1.0 and topographical factor = 1.0, the following table may be used:

Exposure Category	Effective Wind Area	Wind Design Load [psf]															
		85 mph		90 mph		100 mph		110 mph		120 mph		130 mph		140 mph		150 mph	
		Interior Zone	End Zone	Interior Zone	End Zone	Interior Zone	End Zone	Interior Zone	End Zone	Interior Zone	End Zone	Interior Zone	End Zone	Interior Zone	End Zone	Interior Zone	End Zone
B	<=10	14.5	17.9	16.2	20.1	20.1	24.8	24.3	30.0	28.9	35.6	33.9	41.8	39.3	48.5	45.1	55.7
	20	13.9	16.7	15.6	18.7	19.2	23.1	23.3	27.9	27.7	33.2	32.5	39.0	37.7	45.2	43.2	51.9
	50	13.1	15.1	14.7	16.9	18.1	20.9	21.6	25.3	26.1	30.1	30.6	35.3	35.5	40.9	40.8	47.0
	>=100	12.5	13.9	14.0	15.6	17.3	19.2	20.9	23.3	24.9	27.7	29.2	32.5	33.9	37.7	38.9	43.2
C	<=10	20.2	24.9	22.6	27.9	27.9	34.5	33.8	41.7	40.2	49.6	47.2	58.2	54.7	67.5	62.8	77.5
	20	19.3	23.2	21.7	26.0	26.8	32.1	32.4	38.9	38.5	46.3	45.2	54.3	52.4	63.0	60.2	72.3
	50	18.2	21.0	20.4	23.6	25.2	29.1	30.5	35.2	36.3	41.9	42.6	49.1	49.4	57.0	56.8	65.4
	>=100	17.4	19.3	19.5	21.7	24.1	26.8	29.1	32.4	34.6	38.5	40.7	45.2	47.2	52.4	54.1	60.2
D	<=10	23.8	29.4	26.7	32.9	32.9	40.6	39.8	49.2	47.4	58.5	55.6	68.7	64.5	79.6	74.1	91.4
	20	22.8	27.4	25.6	30.7	31.6	37.9	38.2	45.8	45.4	54.6	53.3	64.0	61.8	74.3	71.0	85.3
	50	21.5	24.8	24.1	27.8	29.7	34.3	36.0	41.5	42.8	49.4	50.3	57.9	58.3	67.2	66.9	77.1
	>=100	20.5	22.8	23.0	25.6	28.4	31.5	34.3	38.2	40.9	45.4	48.0	53.3	55.6	61.8	63.8	71.0

- The values shown are based upon the ASCE 7-05 Analytical Procedure, Components & Cladding, Method 2. The corner end zone width of a wall is the smaller of 0.1 x wall length or 0.4 x wall height, but not less than 0.04 x wall length or 3'-0".
- For a mean roof height of 30 feet or less, the stated psf loads in the table above may be reduced 2.5 percent to reflect the values shown in the IRC code.

ASCE 7: A design standard published by the American Society of Civil Engineers (ASCE) that is referenced by the International Building Code (IBC). ASCE 7 – Minimum Design Loads for Buildings and Other Structures establishes the live, snow, seismic and wind loads for the building code.

Components and Cladding (CC): Structural components that do not qualify on their own as a MWFRS (see below). An individual wall stud is an example of a CC element.

Effective Wind Area: A factor used to calculate the wind load on a stud or column. The effective wind area is the greater value of the following two equations:

1. the square of the stud height divided by 3 or $L^2/3$ (see adjacent value table) or
2. the stud height multiplied by the tributary width (or o.c. spacing for studs).

Effective Wind Area	
Wall Height [ft]	Stud/Column Effective Wind Area [ft ²]
>= 18	100
16	85
14	65
12	48
10	33
8	21

Exposure Category: A factor used to calculate the design wind load (pressure) that accounts for the type of terrain surrounding the structure in question. The wind pressure will be less within a housing development versus a structure near a body of water. The following is summary of the exposure categories:

- B = Urban and suburban (subdivision) areas, forest land
- C = Open land with scattered obstructions of heights less than 30 feet
- D = Flat unobstructed areas and water surfaces

In-Plane Loading: Lateral loads applied along the length of the wall are referred to as in-plane loading (see detail below). Wind loading applied parallel to the wall length must be determined by the design professional of record. Bracing, braced wall panels and tie-down anchors at corners shall be determined by design professional of record and be in accordance with applicable building code

Main Wind Force-Resisting System (MWFRS): A classification of structural components. MWFRS generally refers to a system of elements that receives wind loading from more than one surface of the structure. An example of a MWFRS is an exterior wood shear wall. The shear wall receives seismic and wind load along its length (in-plane loading) and wind load perpendicular to its surface (out-of-plane loading).

Out-of-Plane Loading: Wind loading perpendicular to the wall length (see detail below). Tables shown in this guide are based on out-of-plane loading only.

Wind Speed: The value established by the building code or local building department which is then used, along with other factors, to determine the wind load. Wind Speed in ASCE 7 is now based upon a 3 second gust, determined by meteorological data and statistical analysis. Wind speed is provided in units of miles per hour (mph).

Wind Load: The design load used to size a stud or column. The wind load is determined by taking the wind speed and applying all the necessary factors per ASCE 7, including the geometry of the structure, exposure, etc. In some areas, the design wind load is provided for residential construction by the building code jurisdiction. Wind load is in units of pounds per square foot (psf).

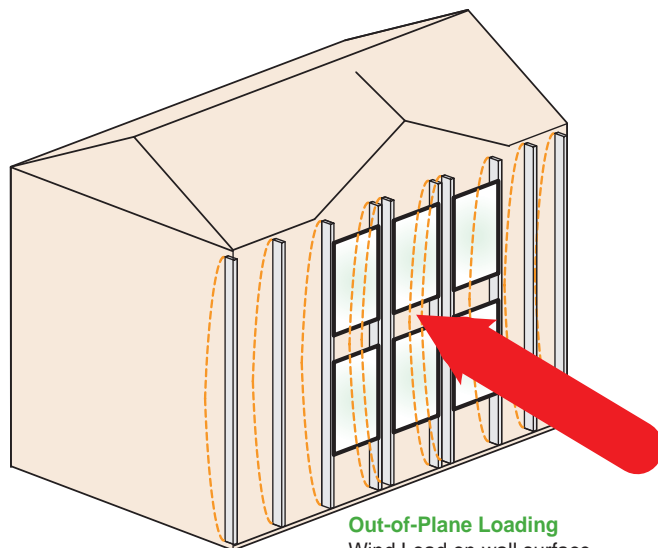

Out-of-Plane Loading
Wind Load on wall surface
Stress and deflection of studs caused by perpendicular loading

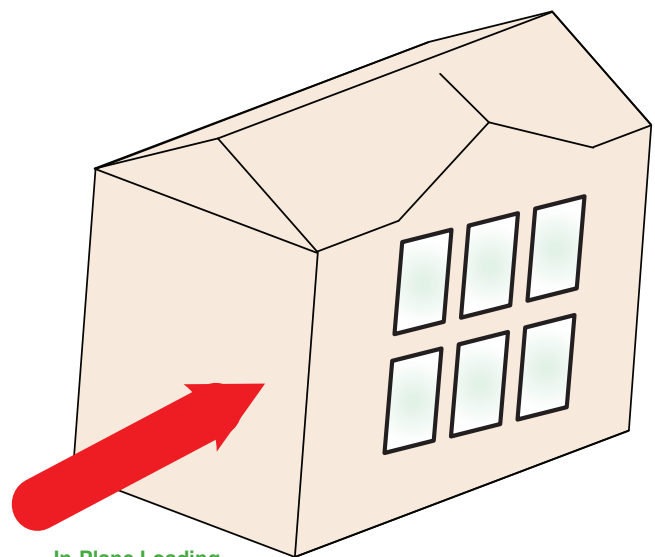

In-Plane Loading
Racking of wall caused by wind and/or seismic loading on opposite wall, applying parallel force on window wall

VERSA-STUD® Design

Given: Wall as shown

Wall Height: 16'-0"

Preliminary Stud Spacing: 16" o.c.

Roof Load: 40 psf snow load, 15 psf dead load. BCI® rafter framing with an 18'-0" horizontal span and 2'-0" overhang

Wind Load: 20 psf load per local building department
(see *wind load section for more information on determining wind loading*)

Deflection Limit: Possible brittle finish = L/240
(IRC Table R301.7)

Solution:

Stud Design

Determine Vertical Load

$$\text{Roof Tributary Width} = [18'-0" / 2] + 2'-0" = 11'-0"$$

$$\text{Snow Load [plf]} = 40 \text{ lb/ft}^2 \times 11 \text{ ft} = 440 \text{ lb/ft}$$

$$\text{Snow Load [lb]} = 440 \text{ lb/ft} \times [16 \text{ in} / 12] = 587 \text{ lb}$$

$$\text{Dead Load [plf]} = 15 \text{ lb/ft}^2 \times 11 \text{ ft} = 165 \text{ lb/ft}$$

$$\text{Wall Weight [lb]} = 10 \text{ lb/ft}^2 \times 16 \text{ ft} \times [16 \text{ in} / 12] = 213 \text{ lb}$$

(assume wall self-weight of 10 psf)

$$\text{Dead Load [lb]} = 165 \text{ lb/ft} \times [16 \text{ in} / 12] = 220 \text{ lb}$$

$$\text{Total Load [lb]} = 587 \text{ lb} + 220 \text{ lb} + 213 \text{ lb} = 1020 \text{ lb}$$

Go to **VERSA-STUD® 1.7 2650 1½" x 5½" load charts, page 10**

L/240, 16 ft wall height

Max. Loading, Single Stud,
Vertical Load = 3609 lb > 1020 lb **OK!**

20 PSF Wind Load, Max. Stud Spacing = 16" **OK!**

VERSA-STUD® 1.7 2650 1½" x 5½" @ 16" o.c. OK!

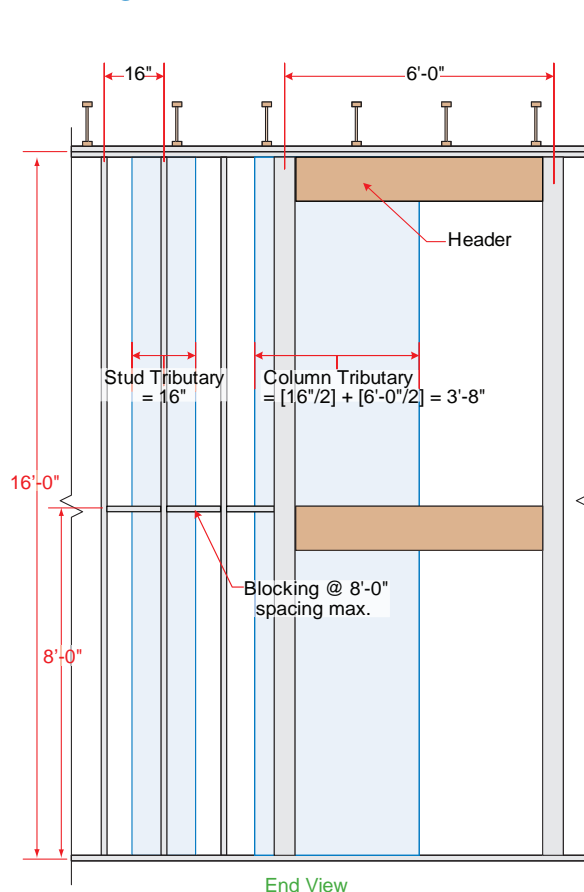

VERSA-LAM® Column Design

Determine Vertical Load

$$\text{Column Tributary Width} = [6'-0" / 2] + [16 \text{ in} / 2] = 3'-8"$$

$$\text{Snow Load [lb]} = 440 \text{ lb/ft} \times 3'-8" = 1615 \text{ lb}$$

$$\text{Dead Load [lb]} = 165 \text{ lb/ft} \times 3'-8" = 606 \text{ lb}$$

$$\text{Total Load [lb]} = 1615 \text{ lb} + 606 \text{ lb} = 2221 \text{ lb}$$

$$\text{Wind Load [plf]} = 20 \text{ lb/ft}^2 \times 3'-8" = 73.4 \text{ lb/ft}$$

Go to **VERSA-LAM® 1.7 2650 Exterior Wall Column Table, page 13**

L/240, 16 ft wall height

3½" x 5¼" Column

$$\text{Vertical Load} = 7358 \text{ lb} > 2221 \text{ lb} \text{ OK!}$$

$$\text{Wind Load} = 55.6 \text{ lb/ft} < 73.4 \text{ lb/ft} \text{ NOT OK}$$

5¼" x 5¼" Column

$$\text{Vertical Load} = 10680 \text{ lb} > 2221 \text{ lb} \text{ OK!}$$

$$\text{Wind Load} = 83.4 \text{ lb/ft} > 73.4 \text{ lb/ft} \text{ OK!}$$

VERSA-LAM® 1.7 2650 Column 5¼" x 5¼" OK!

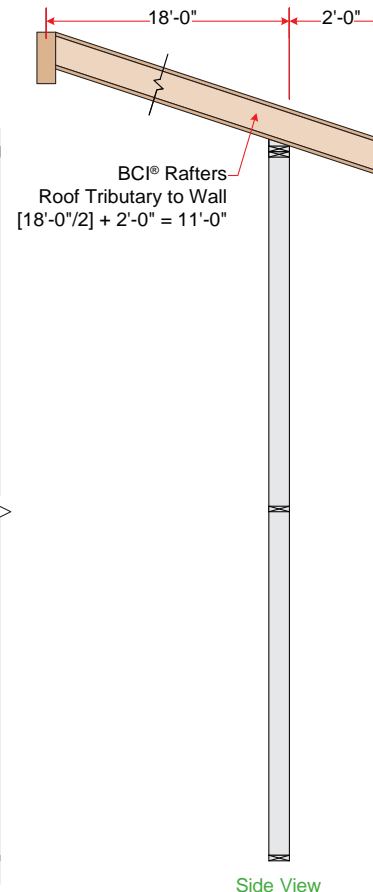

Stud Load Tables

VERSA-STUD® 1.7 2650 1½" x 3½"

Deflection Limit	Wall Height [ft]	MAXIMUM LOADING				10 PSF WIND LOAD SPACING & TRIBUTARY			15 PSF WIND LOAD SPACING & TRIBUTARY			20 PSF WIND LOAD SPACING & TRIBUTARY		
		Single Stud		Double Stud		Single Stud		Double Stud	Single Stud		Double Stud	Single Stud		Double Stud
		Vertical Load [lb]	Wind Load [lb/ft]	Vertical Load [lb]	Wind Load [lb/ft]	Max Stud Spacing [in]	Max Tributary Width [in]	Max Tributary Width [in]	Max Stud Spacing [in]	Max Tributary Width [in]	Max Tributary Width [in]	Max Stud Spacing [in]	Max Tributary Width [in]	Max Tributary Width [in]
L/360	8	2953	37.7	4297	75.3	24	45.2	90.4	24	30.1	60.3	19.2	22.6	45.2
	9	2953	26.5	4262	52.9	24	31.7	63.5	19.2	21.2	42.3	12	15.9	31.7
	10	2672	19.3	4172	38.6	19.2	23.1	46.3	12	15.4	30.9	8	11.6	23.1
	11	2257	14.5	4022	29.0	16	17.4	34.8	8	11.6	23.2	8	8.7	17.4
	12	1931	11.2	3794	22.3	12	13.4	26.8	8	8.9	17.9	6	6.7	13.4
	13	1671	8.8	3309	17.6	8	10.5	21.1	6	7.0	14.0	4	5.3	10.5
	14	1460	7.0	2893	14.1	8	8.4	16.9	4	5.6	11.2	4	4.2	8.4
L/240	8	2953	56.5	3905	113.0	24	67.8	135.6	24	45.2	90.4	24	33.9	67.8
	9	2863	39.7	3879	79.4	24	47.6	95.2	24	31.7	63.5	19.2	23.8	47.6
	10	2405	28.9	3796	57.8	24	34.7	69.4	19.2	23.1	46.3	16	17.4	34.7
	11	2047	21.7	3654	43.5	24	26.1	52.2	16	17.4	34.8	12	13.0	26.1
	12	1764	16.7	3453	33.5	19.2	20.1	40.2	12	13.4	26.8	8	10.0	20.1
	13	1535	13.2	3029	26.3	12	15.8	31.6	8	10.5	21.1	6	7.9	15.8
	14	1348	10.5	2662	21.1	12	12.6	25.3	8	8.4	16.9	6	6.3	12.6
L/180	8	2953	75.3	3512	150.6	24	90.4	180.8	24	60.3	120.5	24	45.2	90.4
	9	2549	52.9	3509	105.8	24	63.5	127.0	24	42.3	84.6	24	31.7	63.5
	10	2168	38.6	3446	77.1	24	46.3	92.6	24	30.9	61.7	19.2	23.1	46.3
	11	1863	29.0	3324	57.9	24	34.8	69.5	19.2	23.2	46.4	16	17.4	34.8
	12	1617	22.3	3151	44.6	24	26.8	53.6	16	17.9	35.7	12	13.4	26.8
	13	1416	17.6	2781	35.1	19.2	21.1	42.1	12	14.0	28.1	8	10.5	21.1
	14	1249	14.1	2459	28.1	16	16.9	33.7	8	11.2	22.5	8	8.4	16.9
L/120	8	2241	113.0	2705	226.0	24	135.6	271.2	24	90.4	180.8	24	67.8	135.6
	9	1979	79.4	2783	158.7	24	95.2	190.4	24	63.5	127.0	24	47.6	95.2
	10	1740	57.8	2782	115.7	24	69.4	138.8	24	46.3	92.6	24	34.7	69.4
	11	1533	43.5	2722	86.9	24	52.2	104.3	24	34.8	69.5	24	26.1	52.2
	12	1356	33.5	2612	67.0	24	40.2	80.3	24	26.8	53.6	19.2	20.1	40.2
	13	1205	26.3	2345	52.7	24	31.6	63.2	19.2	21.1	42.1	12	15.8	31.6
	14	1077	21.1	2100	42.2	24	25.3	50.6	16	16.9	33.7	12	12.6	25.3

Deflection Limit	Wall Height [ft]	MAXIMUM LOADING				25 PSF WIND LOAD SPACING & TRIBUTARY			30 PSF WIND LOAD SPACING & TRIBUTARY			40 PSF WIND LOAD SPACING & TRIBUTARY		
		Single Stud		Double Stud		Single Stud		Double Stud	Single Stud		Double Stud	Single Stud		Double Stud
		Vertical Load [lb]	Wind Load [lb/ft]	Vertical Load [lb]	Wind Load [lb/ft]	Max Stud Spacing [in]	Max Tributary Width [in]	Max Tributary Width [in]	Max Stud Spacing [in]	Max Tributary Width [in]	Max Tributary Width [in]	Max Stud Spacing [in]	Max Tributary Width [in]	Max Tributary Width [in]
L/360	8	2953	37.7	4297	75.3	16	18.1	36.2	12	15.1	30.1	8	11.3	22.6
	9	2953	26.5	4262	52.9	12	12.7	25.4	8	10.6	21.2	6	7.9	15.9
	10	2672	19.3	4172	38.6	8	9.3	18.5	6	7.7	15.4	4	5.8	11.6
	11	2257	14.5	4022	29.0	6	7.0	13.9	4	5.8	11.6	4	4.3	8.7
	12	1931	11.2	3794	22.3	4	5.4	10.7	4	4.5	8.9	--	3.3	6.7
	13	1671	8.8	3309	17.6	4	4.2	8.4	--	3.5	7.0	--	2.6	5.3
	14	1460	7.0	2893	14.1	--	3.4	6.7	--	2.8	5.6	--	2.1	4.2
L/240	8	2953	56.5	3905	113.0	24	27.1	54.2	19.2	22.6	45.2	16	16.9	33.9
	9	2863	39.7	3879	79.4	16	19.0	38.1	12	15.9	31.7	8	11.9	23.8
	10	2405	28.9	3796	57.8	12	13.9	27.8	8	11.6	23.1	8	8.7	17.4
	11	2047	21.7	3654	43.5	8	10.4	20.9	8	8.7	17.4	6	6.5	13.0
	12	1764	16.7	3453	33.5	8	8.0	16.1	6	6.7	13.4	4	5.0	10.0
	13	1535	13.2	3029	26.3	6	6.3	12.6	4	5.3	10.5	--	3.9	7.9
	14	1348	10.5	2662	21.1	4	5.1	10.1	4	4.2	8.4	--	3.2	6.3
L/180	8	2953	75.3	3512	150.6	24	36.2	72.3	24	30.1	60.3	19.2	22.6	45.2
	9	2549	52.9	3509	105.8	24	25.4	50.8	19.2	21.2	42.3	12	15.9	31.7
	10	2168	38.6	3446	77.1	16	18.5	37.0	12	15.4	30.9	8	11.6	23.1
	11	1863	29.0	3324	57.9	12	13.9	27.8	8	11.6	23.2	8	8.7	17.4
	12	1617	22.3	3151	44.6	8	10.7	21.4	8	8.9	17.9	6	6.7	13.4
	13	1416	17.6	2781	35.1	8	8.4	16.9	6	7.0	14.0	4	5.3	10.5
	14	1249	14.1	2459	28.1	6	6.7	13.5	4	5.6	11.2	4	4.2	8.4
L/120	8	2241	113.0	2705	226.0	24	54.2	108.5	24	45.2	90.4	24	33.9	67.8
	9	1979	79.4	2783	158.7	24	38.1	76.2	24	31.7	63.5	19.2	23.8	47.6
	10	1740	57.8	2782	115.7	24	27.8	55.5	19.2	23.1	46.3	16	17.4	34.7
	11	1533	43.5	2722	86.9	19.2	20.9	41.7	16	17.4	34.8	12	13.0	26.1
	12	1356	33.5	2612	67.0	16	16.1	32.1	12	13.4	26.8	8	10.0	20.1
	13	1205	26.3	2345	52.7	12	12.6	25.3	8	10.5	21.1	6	7.9	15.8
	14	1077	21.1	2100	42.2	8	10.1	20.2	8	8.4	16.9	6	6.3	12.6

Notes

- Wall stud analysis per 2005 National Design Specification (NDS) for Wood Construction.
- For 3-ply and 4-ply built up columns, multiply double stud table values by 1.5 and 2.0.
- Full depth blocking required at a maximum spacing of 8'-0" for single studs.
- Structural sheathing or structural siding installed on one side of wall.

- Double stud values assume unsupported lateral length of 7'-0".
- Table assumes wind load duration factor of 1.6 and vertical load duration factor of 1.0.
- Table assumes compression perpendicular to grain for plate of 450 psi.
- Vertical dead load may not exceed 50% of the total vertical load.
- Repetitive member increase for bending (1.04) applied to single studs only.
- Compression perpendicular to grain stress adjusted per NDS 3.10.4 for single studs only.

VERSA-STUD® 1.7 2650 1½" x 5½"

Deflection Limit	Wall Height [ft]	MAXIMUM LOADING				10 PSF WIND LOAD SPACING & TRIBUTARY			15 PSF WIND LOAD SPACING & TRIBUTARY			20 PSF WIND LOAD SPACING & TRIBUTARY		
		Single Stud		Double Stud		Single Stud		Double Stud	Single Stud		Double Stud	Single Stud		Double Stud
		Vertical Load [lb]	Wind Load [lb/ft]	Vertical Load [lb]	Wind Load [lb/ft]	Max Stud Spacing [in]	Max Tributary Width [in]	Max Tributary Width [in]	Max Stud Spacing [in]	Max Tributary Width [in]	Max Tributary Width [in]	Max Stud Spacing [in]	Max Tributary Width [in]	Max Tributary Width [in]
L/360	10	4641	74.8	6615	149.6	24	89.8	179.6	24	59.9	119.7	24	44.9	89.8
	12	4641	43.3	6676	86.6	24	52.0	103.9	24	34.6	69.3	24	26.0	52.0
	14	4641	27.3	6624	54.5	24	32.7	65.4	19.2	21.8	43.6	16	16.4	32.7
	16	4025	18.3	6442	36.5	19.2	21.9	43.8	12	14.6	29.2	8	11.0	21.9
	17	3615	15.2	6291	30.5	16	18.3	36.6	12	12.2	24.4	8	9.1	18.3
	18	3266	12.8	6093	25.7	12	15.4	30.8	8	10.3	20.5	6	7.7	15.4
	19	2965	10.9	5850	21.8	12	13.1	26.2	8	8.7	17.5	6	6.5	13.1
20	2704	9.4	5337	18.7	8	11.2	22.4	6	7.5	15.0	4	5.6	11.2	
L/240	10	4641	112.2	5870	224.5	24	134.7	269.4	24	89.8	179.6	24	67.3	134.7
	12	4641	65.0	6006	129.9	24	77.9	155.9	24	52.0	103.9	24	39.0	77.9
	14	4493	40.9	5987	81.8	24	49.1	98.2	24	32.7	65.4	24	24.5	49.1
	16	3609	27.4	5822	54.8	24	32.9	65.8	19.2	21.9	43.8	16	16.4	32.9
	17	3261	22.8	5682	45.7	24	27.4	54.8	16	18.3	36.6	12	13.7	27.4
	18	2960	19.2	5507	38.5	19.2	23.1	46.2	12	15.4	30.8	8	11.5	23.1
	19	2699	16.4	5296	32.7	19.2	19.6	39.3	12	13.1	26.2	8	9.8	19.6
20	2471	14.0	4854	28.1	16	16.8	33.7	8	11.2	22.4	8	8.4	16.8	
L/180	10	4641	149.6	5077	299.3	24	179.6	359.2	24	119.7	239.4	24	89.8	179.6
	12	4641	86.6	5326	173.2	24	103.9	207.8	24	69.3	138.6	24	52.0	103.9
	14	3968	54.5	5368	109.1	24	65.4	130.9	24	43.6	87.3	24	32.7	65.4
	16	3242	36.5	5247	73.1	24	43.8	87.7	24	29.2	58.5	19.2	21.9	43.8
	17	2948	30.5	5131	60.9	24	36.6	73.1	24	24.4	48.7	16	18.3	36.6
	18	2691	25.7	4982	51.3	24	30.8	61.6	19.2	20.5	41.1	12	15.4	30.8
	19	2465	21.8	4807	43.6	24	26.2	52.4	16	17.5	34.9	12	13.1	26.2
20	2267	18.7	4427	37.4	19.2	22.4	44.9	12	15.0	29.9	8	11.2	22.4	
L/120	10	3704	224.5	3254	448.9	24	269.4	538.7	24	179.6	359.2	24	134.7	269.4
	12	3459	129.9	3887	259.8	24	155.9	311.8	24	103.9	207.8	24	77.9	155.9
	14	3009	81.8	4135	163.6	24	98.2	196.3	24	65.4	130.9	24	49.1	98.2
	16	2577	54.8	4166	109.6	24	65.8	131.5	24	43.8	87.7	24	32.9	65.8
	17	2385	45.7	4119	91.4	24	54.8	109.7	24	36.6	73.1	24	27.4	54.8
	18	2207	38.5	4040	77.0	24	46.2	92.4	24	30.8	61.6	19.2	23.1	46.2
	19	2049	32.7	3934	65.5	24	39.3	78.5	24	26.2	52.4	19.2	19.6	39.3
20	1903	28.1	3666	56.1	24	33.7	67.3	19.2	22.4	44.9	16	16.8	33.7	

Deflection Limit	Wall Height [ft]	MAXIMUM LOADING				25 PSF WIND LOAD SPACING & TRIBUTARY			30 PSF WIND LOAD SPACING & TRIBUTARY			40 PSF WIND LOAD SPACING & TRIBUTARY		
		Single Stud		Double Stud		Single Stud		Double Stud	Single Stud		Double Stud	Single Stud		Double Stud
		Vertical Load [lb]	Wind Load [lb/ft]	Vertical Load [lb]	Wind Load [lb/ft]	Max Stud Spacing [in]	Max Tributary Width [in]	Max Tributary Width [in]	Max Stud Spacing [in]	Max Tributary Width [in]	Max Tributary Width [in]	Max Stud Spacing [in]	Max Tributary Width [in]	Max Tributary Width [in]
L/360	10	4641	74.8	6615	149.6	24	35.9	71.8	24	29.9	59.9	19.2	22.4	44.9
	12	4641	43.3	6676	86.6	19.2	20.8	41.6	16	17.3	34.6	12	13.0	26.0
	14	4641	27.3	6624	54.5	12	13.1	26.2	8	10.9	21.8	8	8.2	16.4
	16	4027	18.3	6442	36.5	8	8.8	17.5	6	7.3	14.6	4	5.5	11.0
	17	3617	15.2	6291	30.5	6	7.3	14.6	6	6.1	12.2	4	4.6	9.1
	18	3267	12.8	6093	25.7	6	6.2	12.3	4	5.1	10.3	--	3.8	7.7
	19	2966	10.9	5850	21.8	4	5.2	10.5	4	4.4	8.7	--	3.3	6.5
20	2704	9.4	5337	18.7	4	4.5	9.0	--	3.7	7.5	--	2.8	5.6	
L/240	10	4641	112.2	5870	224.5	24	53.9	107.7	24	44.9	89.8	24	33.7	67.3
	12	4641	65.0	6006	129.9	24	31.2	62.4	24	26.0	52.0	19.2	19.5	39.0
	14	4493	40.9	5987	81.8	19.2	19.6	39.3	16	16.4	32.7	12	12.3	24.5
	16	3610	27.4	5822	54.8	12	13.2	26.3	8	11.0	21.9	8	8.2	16.4
	17	3261	22.8	5682	45.7	8	11.0	21.9	8	9.1	18.3	6	6.9	13.7
	18	2961	19.2	5507	38.5	8	9.2	18.5	6	7.7	15.4	4	5.8	11.5
	19	2699	16.4	5296	32.7	6	7.9	15.7	6	6.5	13.1	4	4.9	9.8
20	2471	14.0	4854	28.1	6	6.7	13.5	4	5.6	11.2	4	4.2	8.4	
L/180	10	4641	149.6	5077	299.3	24	71.8	143.7	24	59.9	119.7	24	44.9	89.8
	12	4641	86.6	5326	173.2	24	41.6	83.1	24	34.6	69.3	24	26.0	52.0
	14	3968	54.5	5368	109.1	24	26.2	52.4	19.2	21.8	43.6	16	16.4	32.7
	16	3242	36.5	5247	73.1	16	17.5	35.1	12	14.6	29.2	8	11.0	21.9
	17	2948	30.5	5131	60.9	12	14.6	29.2	12	12.2	24.4	8	9.1	18.3
	18	2691	25.7	4982	51.3	12	12.3	24.6	8	10.3	20.5	6	7.7	15.4
	19	2466	21.8	4807	43.6	8	10.5	20.9	8	8.7	17.5	6	6.5	13.1
20	2267	18.7	4427	37.4	8	9.0	18.0	6	7.5	15.0	4	5.6	11.2	
L/120	10	3705	224.5	3254	448.9	24	107.7	215.5	24	89.8	179.6	24	67.3	134.7
	12	3459	129.9	3887	259.8	24	62.4	124.7	24	52.0	103.9	24	39.0	77.9
	14	3008	81.8	4135	163.6	24	39.3	78.5	24	32.7	65.4	24	24.5	49.1
	16	2577	54.8	4166	109.6	24	26.3	52.6	19.2	21.9	43.8	16	16.4	32.9
	17	2384	45.7	4119	91.4	19.2	21.9	43.9	16	18.3	36.6	12	13.7	27.4
	18	2209	38.5	4040	77.0	16	18.5	37.0	12	15.4	30.8	8	11.5	23.1
	19	2049	32.7	3934	65.5	12	15.7	31.4	12	13.1	26.2	8	9.8	19.6
20	1904	28.1	3666	56.1	12	13.5	26.9	8	11.2	22.4	8	8.4	16.8	

- Notes**
- Wall stud analysis per 2005 National Design Specification (NDS) for Wood Construction.
 - For 3-ply and 4-ply built up columns, multiply double stud table values by 1.5 and 2.0.
 - Full depth blocking required at a maximum spacing of 8'-0" for single studs.
 - Structural sheathing or structural siding installed on one side of wall.

- Double stud values assume unsupported lateral length of 7'-0".
- Table assumes wind load duration factor of 1.6 and vertical load duration factor of 1.0.
- Table assumes compression perpendicular to grain for plate of 450 psi.
- Vertical dead load may not exceed 50% of the total vertical load.
- Repetitive member increase for bending (1.04) applied to single studs only.
- Compression perpendicular to grain stress adjusted per NDS 3.10.4 for single studs only.

Stud Load Tables

VERSA-STUD® 1.7 2650 1½" x 7¼"

Deflection Limit	Wall Height [ft]	MAXIMUM LOADING				10 PSF WIND LOAD SPACING & TRIBUTARY			15 PSF WIND LOAD SPACING & TRIBUTARY			20 PSF WIND LOAD SPACING & TRIBUTARY		
		Single Stud		Double Stud		Single Stud		Double Stud	Single Stud		Double Stud	Single Stud		Double Stud
		Vertical Load [lb]	Wind Load [lb/ft]	Vertical Load [lb]	Wind Load [lb/ft]	Max Stud Spacing [in]	Max Tributary Width [in]	Max Tributary Width [in]	Max Stud Spacing [in]	Max Tributary Width [in]	Max Tributary Width [in]	Max Stud Spacing [in]	Max Tributary Width [in]	Max Tributary Width [in]
L/360	10	6117	171.4	8249	342.8	24	205.7	411.3	24	137.1	274.2	24	102.8	205.7
	12	6117	99.2	8529	198.4	24	119.0	238.0	24	79.3	158.7	24	59.5	119.0
	14	6117	62.5	8669	124.9	24	74.9	149.9	24	50.0	99.9	24	37.5	74.9
	16	6117	41.8	8713	83.7	24	50.2	100.4	24	33.5	66.9	24	25.1	50.2
	18	6117	29.4	8669	58.8	24	35.3	70.5	19.2	23.5	47.0	16	17.6	35.3
	20	5782	21.4	8529	42.8	24	25.7	51.4	16	17.1	34.3	12	12.9	25.7
	22	4892	16.1	8278	32.2	19.2	19.3	38.6	12	12.9	25.8	8	9.7	19.3
24	4192	12.4	7888	24.8	12	14.9	29.8	8	9.9	19.8	6	7.4	14.9	
L/240	10	6117	257.1	6911	514.2	24	308.5	617.0	24	205.7	411.3	24	154.2	308.5
	12	6117	148.8	7405	297.5	24	178.5	357.1	24	119.0	238.0	24	89.3	178.5
	14	6117	93.7	7675	187.4	24	112.4	224.8	24	74.9	149.9	24	56.2	112.4
	16	6117	62.8	7791	125.5	24	75.3	150.6	24	50.2	100.4	24	37.7	75.3
	18	6093	44.1	7786	88.2	24	52.9	105.8	24	35.3	70.5	24	26.4	52.9
	20	5141	32.1	7668	64.3	24	38.6	77.1	24	25.7	51.4	19.2	19.3	38.6
	22	4392	24.1	7437	48.3	24	29.0	57.9	19.2	19.3	38.6	12	14.5	29.0
24	3794	18.6	7099	37.2	19.2	22.3	44.6	12	14.9	29.8	8	11.2	22.3	
L/180	10	6117	342.8	5354	685.5	24	411.3	822.6	24	274.2	548.4	24	205.7	411.3
	12	6117	198.4	6183	396.7	24	238.0	476.1	24	158.7	317.4	24	119.0	238.0
	14	6117	124.9	6627	249.8	24	149.9	299.8	24	99.9	199.9	24	74.9	149.9
	16	6117	83.7	6853	167.4	24	100.4	200.8	24	66.9	133.9	24	50.2	100.4
	18	5334	58.8	6919	117.5	24	70.5	141.1	24	47.0	94.0	24	35.3	70.5
	20	4571	42.8	6855	85.7	24	51.4	102.8	24	34.3	68.6	24	25.7	51.4
	22	3947	32.2	6675	64.4	24	38.6	77.3	24	25.8	51.5	19.2	19.3	38.6
24	3441	24.8	6397	49.6	24	29.8	59.5	19.2	19.8	39.7	12	14.9	29.8	
L/120	10	6117	408.5	3869	785.7	24	490.3	942.8	24	326.8	628.5	24	245.1	471.4
	12	4901	283.7	3603	545.6	24	340.5	654.7	24	227.0	436.5	24	170.2	327.4
	14	4589	187.4	4258	374.7	24	224.8	449.7	24	149.9	299.8	24	112.4	224.8
	16	4349	125.5	4863	251.1	24	150.6	301.3	24	100.4	200.8	24	75.3	150.6
	18	3948	88.2	5168	176.3	24	105.8	211.6	24	70.5	141.1	24	52.9	105.8
	20	3533	64.3	5284	128.5	24	77.1	154.2	24	51.4	102.8	24	38.6	77.1
	22	3150	48.3	5258	96.6	24	57.9	115.9	24	38.6	77.3	24	29.0	57.9
24	2812	37.2	5124	74.4	24	44.6	89.3	24	29.8	59.5	19.2	22.3	44.6	

Deflection Limit	Wall Height [ft]	MAXIMUM LOADING				25 PSF WIND LOAD SPACING & TRIBUTARY			30 PSF WIND LOAD SPACING & TRIBUTARY			40 PSF WIND LOAD SPACING & TRIBUTARY		
		Single Stud		Double Stud		Single Stud		Double Stud	Single Stud		Double Stud	Single Stud		Double Stud
		Vertical Load [lb]	Wind Load [lb/ft]	Vertical Load [lb]	Wind Load [lb/ft]	Max Stud Spacing [in]	Max Tributary Width [in]	Max Tributary Width [in]	Max Stud Spacing [in]	Max Tributary Width [in]	Max Tributary Width [in]	Max Stud Spacing [in]	Max Tributary Width [in]	Max Tributary Width [in]
L/360	10	6117	171.4	8249	342.8	24	82.3	164.5	24	68.6	137.1	24	51.4	102.8
	12	6117	99.2	8529	198.4	24	47.6	95.2	24	39.7	79.3	24	29.8	59.5
	14	6117	62.5	8669	124.9	24	30.0	60.0	24	25.0	50.0	16	18.7	37.5
	16	6117	41.8	8713	83.7	19.2	20.1	40.2	16	16.7	33.5	12	12.6	25.1
	18	6117	29.4	8669	58.8	12	14.1	28.2	8	11.8	23.5	8	8.8	17.6
	20	5782	21.4	8529	42.8	8	10.3	20.6	8	8.6	17.1	6	6.4	12.9
	22	4892	16.1	8278	32.2	6	7.7	15.5	6	6.4	12.9	4	4.8	9.7
24	4192	12.4	7888	24.8	4	6.0	11.9	4	5.0	9.9	--	3.7	7.4	
L/240	10	6117	257.1	6911	514.2	24	123.4	246.8	24	102.8	205.7	24	77.1	154.2
	12	6117	148.8	7405	297.5	24	71.4	142.8	24	59.5	119.0	24	44.6	89.3
	14	6117	93.7	7675	187.4	24	45.0	89.9	24	37.5	74.9	24	28.1	56.2
	16	6117	62.8	7791	125.5	24	30.1	60.3	24	25.1	50.2	16	18.8	37.7
	18	6093	44.1	7786	88.2	19.2	21.2	42.3	16	17.6	35.3	12	13.2	26.4
	20	5141	32.1	7668	64.3	12	15.4	30.8	12	12.9	25.7	8	9.6	19.3
	22	4392	24.1	7437	48.3	8	11.6	23.2	8	9.7	19.3	6	7.2	14.5
24	3794	18.6	7099	37.2	8	8.9	17.9	6	7.4	14.9	4	5.6	11.2	
L/180	10	6117	342.8	5354	685.5	24	164.5	329.1	24	137.1	274.2	24	102.8	205.7
	12	6117	198.4	6183	396.7	24	95.2	190.4	24	79.3	158.7	24	59.5	119.0
	14	6117	124.9	6627	249.8	24	60.0	119.9	24	50.0	99.9	24	37.5	74.9
	16	6117	83.7	6853	167.4	24	40.2	80.3	24	33.5	66.9	24	25.1	50.2
	18	5334	58.8	6919	117.5	24	28.2	56.4	19.2	23.5	47.0	16	17.6	35.3
	20	4571	42.8	6855	85.7	19.2	20.6	41.1	16	17.1	34.3	12	12.9	25.7
	22	3947	32.2	6675	64.4	12	15.5	30.9	12	12.9	25.8	8	9.7	19.3
24	3441	24.8	6397	49.6	8	11.9	23.8	8	9.9	19.8	6	7.4	14.9	
L/120	10	6117	408.5	3869	785.7	24	196.1	377.1	24	163.4	314.3	24	122.6	235.7
	12	4901	283.7	3603	545.6	24	136.2	261.9	24	113.5	218.2	24	85.1	163.7
	14	4589	187.4	4258	374.7	24	89.9	179.9	24	74.9	149.9	24	56.2	112.4
	16	4349	125.5	4863	251.1	24	60.3	120.5	24	50.2	100.4	24	37.7	75.3
	18	3948	88.2	5168	176.3	24	42.3	84.6	24	35.3	70.5	24	26.4	52.9
	20	3533	64.3	5284	128.5	24	30.8	61.7	24	25.7	51.4	19.2	19.3	38.6
	22	3150	48.3	5258	96.6	19.2	23.2	46.4	19.2	19.3	38.6	12	14.5	29.0
24	2812	37.2	5124	74.4	16	17.9	35.7	12	14.9	29.8	8	11.2	22.3	

Notes

- Wall stud analysis per 2005 National Design Specification (NDS) for Wood Construction.
- For 3-ply and 4-ply built up columns, multiply double stud table values by 1.5 and 2.0.
- Full depth blocking required at a maximum spacing of 8'-0" for single studs.
- Structural sheathing or structural siding installed on one side of wall.

- Double stud values assume unsupported lateral length of 7'-0".
- Table assumes wind load duration factor of 1.6 and vertical load duration factor of 1.0.
- Table assumes compression perpendicular to grain for plate of 450 psi.
- Vertical dead load may not exceed 50% of the total vertical load.
- Repetitive member increase for bending (1.04) applied to single studs only.
- Compression perpendicular to grain stress adjusted per NDS 3.10.4 for single studs only.

Multiple-Ply Stud Connections

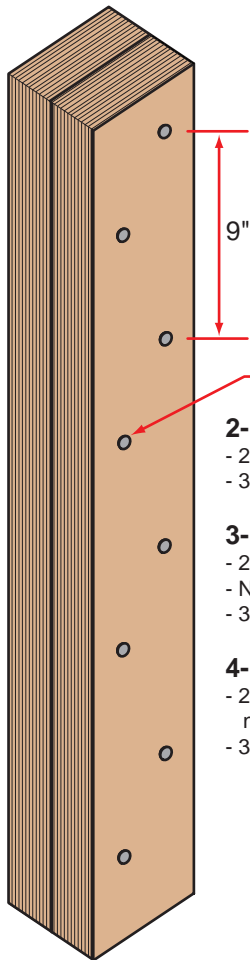

- Stagger rows
- 2-Ply 1 1/2" Connection**
 - 2 rows 10d (min) nails @ 9" o.c.
 - 3 rows for 9/4" and greater studs
- 3-Ply 1 1/2" Connection**
 - 2 rows 10d (min) nails @ 9" o.c.
 - Nail from each side
 - 3 rows for 9/4" and greater studs
- 4-Ply 1 1/2" Connection**
 - 2 rows 10d (min) nails @ 9" o.c.,
 nailed from each ply to each ply
 - 3 rows for 9/4" and greater studs

Header to Column

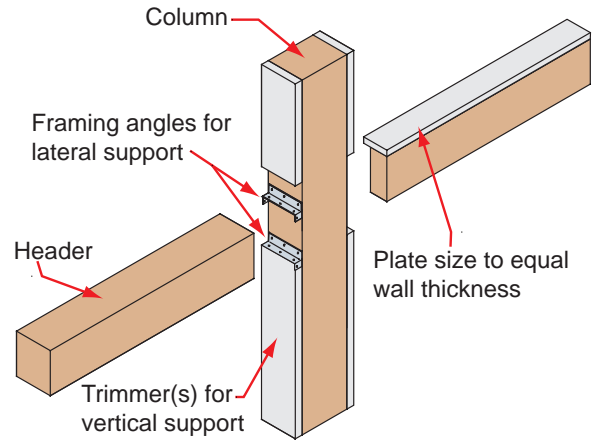

Column to Bottom Plate

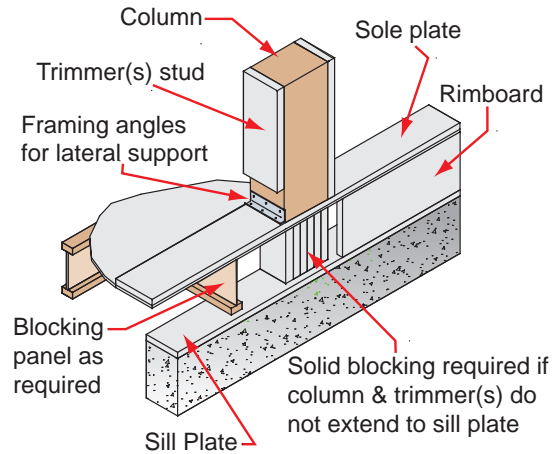

3 1/2" Studs - 24" o.c.

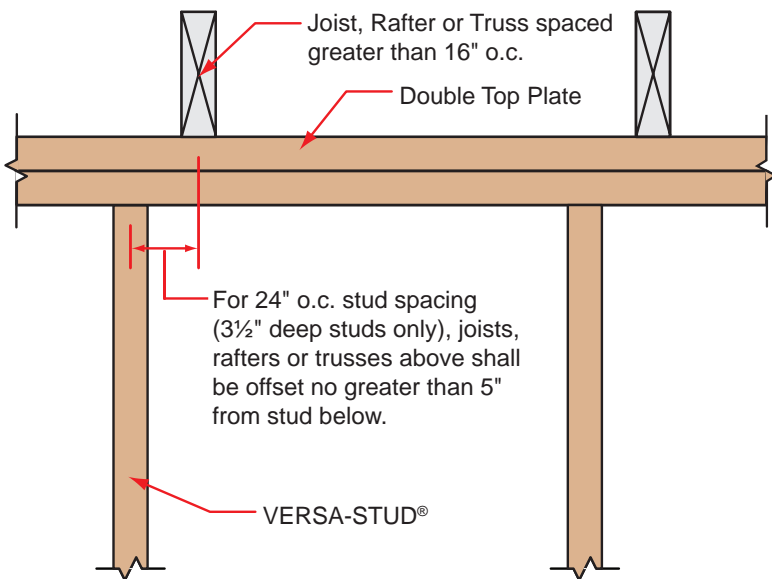

Column to Top Plate

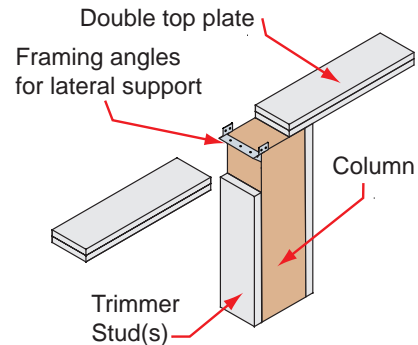

Deflection Limit	Column Height [ft]	3½" Thick Wall						5½" Thick Wall						7¼" Thick Wall								
		3½" x 3½"		5¼" x 3½"		7" x 3½"		3½" x 5¼"		5¼" x 5¼"		7" x 5¼"		3½" x 7"		5¼" x 7"		7" x 7"				
		Vertical Load [lb]	Wind Load [lb/ft]	Vertical Load [lb]	Wind Load [lb/ft]	Vertical Load [lb]	Wind Load [lb/ft]	Vertical Load [lb]	Wind Load [lb/ft]	Vertical Load [lb]	Wind Load [lb/ft]	Vertical Load [lb]	Wind Load [lb/ft]	Vertical Load [lb]	Wind Load [lb/ft]	Vertical Load [lb]	Wind Load [lb/ft]	Vertical Load [lb]	Wind Load [lb/ft]			
L/360	7	5513	131.2	8269	196.8	11025	262.3	8269	442.7	12403	664.1	16538	885.4	11025	1049.4	16538	1574.1	22050	2098.8			
	24																					
	L/240	7	5513	196.8	8269	295.1	11025	393.5	8269	664.1	12403	996.1	16538	1328.1	11025	1574.1	16538	2361.1	22050	3148.1		
		24																				
		L/180	7	5513	262.3	8269	393.5	11025	524.7	8269	885.4	12403	1328.1	16538	1770.8	11025	1697.2	16538	2598.3	22050	3171.0	
			24																			
			L/120	7	4634	393.5	6936	590.3	9266	787.0	8269	996.9	12403	1381.2	16538	1841.6	11025	1697.2	16538	2598.3	22050	3171.0
				24																		

- Notes**
- Column analysis per 2005 National Design Specification (NDS) for Wood Construction.
 - Allowable loads are based upon one-piece (solid) columns used in dry service conditions.
 - Install columns with depth (second dimension listed in table) matching wall thickness.

- Load values are not shown for longer lengths if the controlling slenderness ratio exceeds 50 (per NDS)
- Full depth blocking required at a maximum spacing of 8'-0"
- Table assumes wind load duration of 1.6 and axial load duration of 1.0.
- Vertical dead load may not exceed 50% of the total vertical load.
- Table assumes compression perpendicular to grain for plate of 450 psi.

VERSA-STUD® 1.7 2650 Nail Design Values

Nail Type	Nail Diameter	Nail Length	Lateral Capacity [lb]	Lateral End Grain Capacity [lb]	Lateral Toe-Nail Capacity [lb]
8d box	0.113"	2.5"	116	78	96
8d common	0.131"	2.5"	143	96	119
10d box	0.128"	3"	148	99	123
10d common	0.148"	3"	188	126	156
12d box	0.128"	3.25"	148	99	123
12d common	0.148"	3.25"	188	126	156
16d box	0.135"	3.5"	165	111	137
16d sinker	0.148"	3.25"	188	126	156
16d common	0.162"	3.5"	225	151	187

Notes

- Nail values per 2005 National Design Specification (NDS) for Wood Construction.
- Nail values based upon a load duration factor of 1.60 and an equivalent specific gravity of 0.5.

- Lateral capacities based upon a side-member thickness of 1½".
- For end grain connections, a reduction factor of 0.67 is applied (NDS 11.5.2).
- For toe-nailed connections, a reduction factor of 0.83 is applied (NDS 11.5.4).

Wall Connectors

FRAMING ANGLES

Simpson Strong-Tie

Model No.	Length	Stud Size	Nailing	Allowable Load [lb]	
				F1	F2
A23	2¾"	3½"	(8) 10d x 1½"	565	585
A34	2½"	3½"	(8) 8d x 1½"	365	280
L30	3"	3½"	(4) 10d	240	240
LS30	3¾"	3½"	(6) 10d	395	-
L50	5"	5½"	(6) 10d	445	445
LS50	4⅞"	5½"	(8) 10d	560	-
L70	7"	7¼"	(8) 10d	565	565
LS70	6¾"	7¼"	(10) 10d	665	-
L70	7"	7¼"	(8) 10d	565	565

USP Structural Connectors

Model No.	Length	Stud Size	Nailing	Allowable Load [lb]	
				F1	F2
A3	2¾"	3½"	(8) 10d x 1½"	590	600
AC3	2⅞"	3½"	(4) 10d x 1½"	285	320
MP3	3¾"	3½"	(6) 10d	485	-
AC5	4⅞"	5½"	(6) 10d x 1½"	555	555
MP5	4⅝"	5½"	(8) 10d	730	-
AC7	6⅝"	7¼"	(8) 10d	740	740
L70	5⅞"	7¼"	(10) 10d	910	-

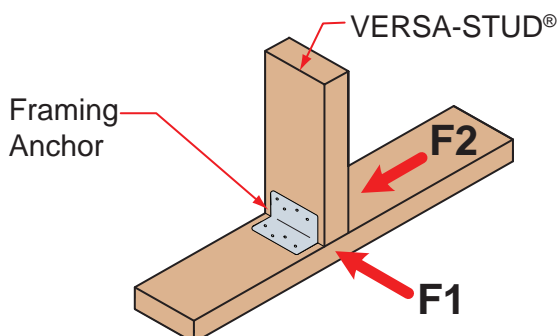

STUD/PLATE TIES

Simpson Strong-Tie

Model No.	Nailing	Uplift [lb]
RSP4	(8) 8d x 1½"	315
SSP	(7) 10d x 1½"	350
DSP	(14) 10d x 1½"	775
SP1	(10) 10d	585
SP2	(12) 10d	1065

USP Structural Connectors

Model No.	Nailing	Uplift [lb]
RSPT4	(8) 8d x 1½"	470
RSPT6	(8) 10d x 1½"	700
RSPT6-2	(14) 10d x 1½"	955
SPT22	(8) 10d	725
SPT24	(12) 10d	1085

HEADER CLIPS/HANGERS

Simpson Strong-Tie

Model No.	Width	Nailing	Allow Vertical Load [lb]
FC4	3 ⁹ / ₁₆ "	(8) 16d	800
FC6	5½"	(10) 16d	920
HH4	3½"	(13) 16d	1195
HH6	5½"	(18) 16d	1595

USP Structural Connectors

Model No.	Width	Nailing	Allow Vertical Load [lb]
SFC4	3 ⁹ / ₁₆ "	(8) 16d	550
SFC6	5½"	(10) 16d	690
HH44	3 ⁹ / ₁₆ "	(13) 16d	1240
HH66	5½"	(18) 16d	1650

Connection values based upon a load duration factor of 1.6 and an equivalent specific gravity of 0.5.

Base and Top Lateral Wind Reactions for Connectors [lb] 20 PSF Wind Load

See footnote 1 for conversions for other wind loads

Height [ft]	Stud / Column Tributary Width [in]										Note
	12	16	19.2	24	36	48	60	72	84	96	
8	80	107	128	160	240	320	400	480	560	640	1) For other wind loads, multiply reaction in table by the following factors: 10 PSF = 0.5 15 PSF = 0.75 25 PSF = 1.25 30 PSF = 1.5 40 PSF = 2.0
10	100	133	160	200	300	400	500	600	700	800	
12	120	160	192	240	360	480	600	720	840	960	
14	140	187	224	280	420	560	700	840	980	1120	
16	160	213	256	320	480	640	800	960	1120	1280	
18	180	240	288	360	540	720	900	1080	1260	1440	
20	200	267	320	400	600	800	1000	1200	1400	1600	
22	220	293	352	440	660	880	1100	1320	1540	1760	
24	240	320	384	480	720	960	1200	1440	1680	1920	

VERSA-STUD® Allowable Holes and Notches

Prescriptive Provisions

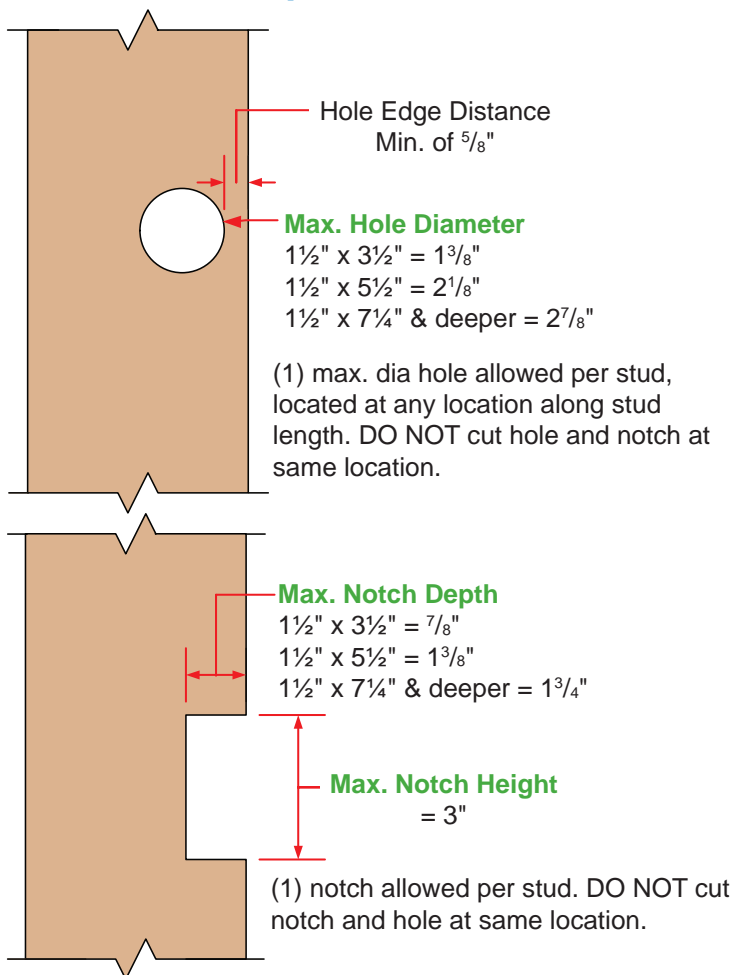

Notes:

- 1) Provisions valid only for studs within prescriptive design (see page 3).
- 2) Shield plates or nail stops to prevent nailing into wiring or piping shall be installed per the governing building code.

Engineered Design Provisions

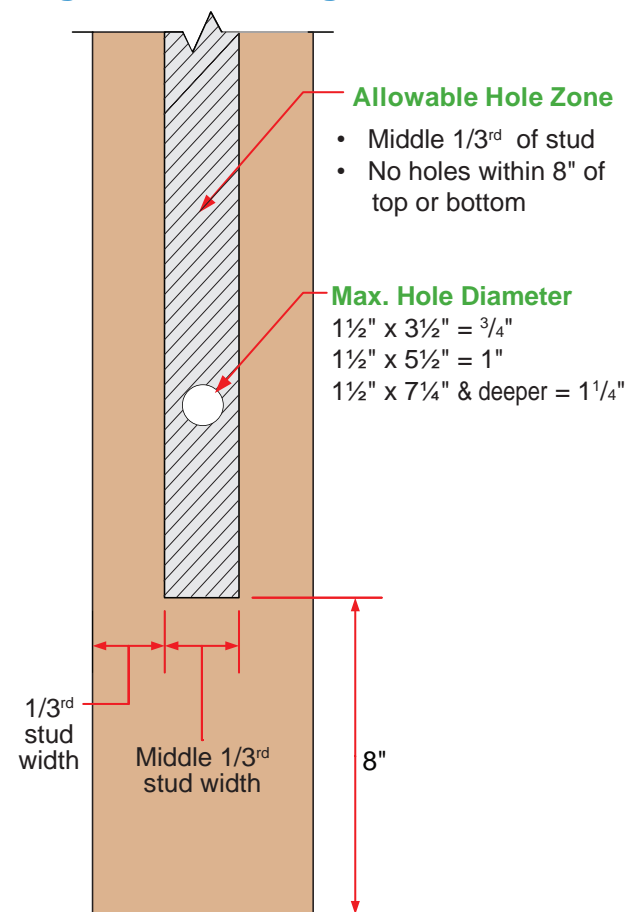

Notes:

- 1) DO NOT drill more than 3 holes in any 4-foot-long section of stud.
- 2) The vertical distance between adjacent holes must be at least 2 times the size of the larger hole
- 3) Holes no greater than $\frac{3}{4}$ " dia may be cut in the hole zone shown in VERSA-LAM® columns.
- 4) For notches and larger holes, contact Boise EWP Engineering.

1½" VERSA-STUD® 1.7 2650 Design Properties

Width [in]	Depth [in]	Weight [lb/ft]	Allowable Shear [lb]	Allowable Moment [lb-ft]	Moment of Inertia (I) [in ⁴]
1½	3½	1.5	998	776	5.4
1½	5½	2.4	1568	1821	20.8
1½	7¼	3.2	2066	3069	47.6
1½	9¼	4.0	2636	4862	98.9
1½	11¼	4.9	3206	7038	178.0

VERSA-LAM® 1.7 2650 Column Design Properties

Width [in]	Depth [in]	Weight [lb/ft]	Allowable Moment Edge ⁽¹⁾ [lb-ft]	Allowable Moment Flat ⁽¹⁾ [lb-ft]	Moment of Inertia (I) [in ⁴]
3½	3½	3.6	1810	1639	12.5
3½	5¼	5.4	3892	3525	42.2
3½	7	7.1	6702	6069	100.0
5¼	5¼	8.0	5838	5287	63.3
5¼	7	10.7	10053	9104	150.1
7	7	14.3	13403	12139	200.1

1) Allowable bending stress is 2650 psi on edge (parallel to gluelines), 2400 psi flat (perpendicular to gluelines)

Allowable Stress Value Comparison

Product	Bending F_b [psi]	Compression Parallel to Grain F_c [psi]	Compression Perp to Grain $F_{c\perp}$ [psi]	Modulus of Elasticity E [psi]	Horizontal Shear F_v [psi]
VERSA-STUD® 1.7 2650	2650	3000	450	1700000	285
Spruce Pine Fir (North) #1/2 Grade	875	1150	425	1400000	135
Hem-Fir #2 Grade	850	1300	405	1300000	150
Western Woods #2 Grade	675	900	335	1000000	135

- Design values are for loads applied to the narrow face of the studs.
- Dimension lumber values taken from 2005 Edition, NDS Design Values for Wood Construction. (per 2006 IBC/IRC)
- Repetitive member and size factors have not been applied.



Prescriptive Nailing

Since VERSA-STUD® may be used in prescriptive design in the IBC and IRC, it may be installed as studs in braced wall panels. Standard nailing for prescriptive wood stud walls with structural sheathing is 6d common nails for panels $\frac{5}{16}$ " to $\frac{1}{2}$ " thick, 8d common nails for panels $\frac{19}{32}$ " to 1" thick, spaced at 6" on-center on panel edges and 12" on-center in intermediate studs.

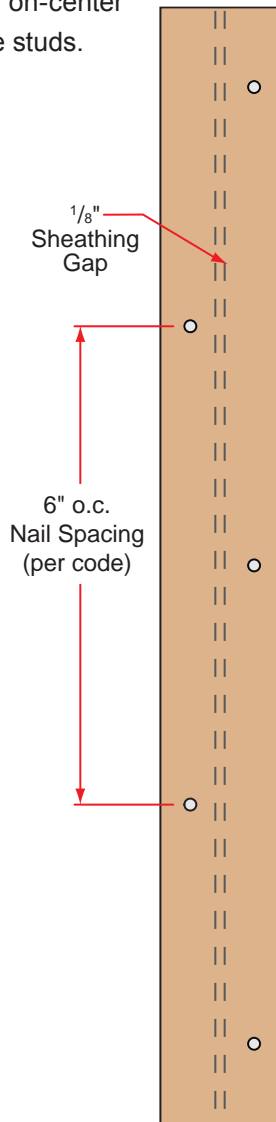

Single Stud Nailing at Panel Edges

Shear Walls

VERSA-STUD® may be used in shear wall construction. Allowable shear values may be determined by using Table 2306.4.1 of the IBC, shear walls with Douglas fir-Larch framing, subject to the following conditions:

1. A double VERSA-STUD® must be used at all panel edges of shear walls. Studs must be stitch-nailed together with two rows of 10d common nails at 8" on-center, staggered.
2. Nails at panel edges must be staggered along two nailing lines spaced approximately $\frac{1}{2}$ " apart. Nails at panel edges must also be at least $\frac{3}{8}$ " from the edges of the VERSA-STUD® and the wood structural panel (see detail below).
3. The tabulated shear values for nailed wood structural panel shear walls using 8d or 10d box or common nails at a panel edge nailing of 2" must be multiplied by a factor of 0.9.
4. The tabulated shear values for nailed wood structural panel shear walls using 10d box or common nails at a panel edge nailing of 3" must be multiplied by a factor of 0.9.

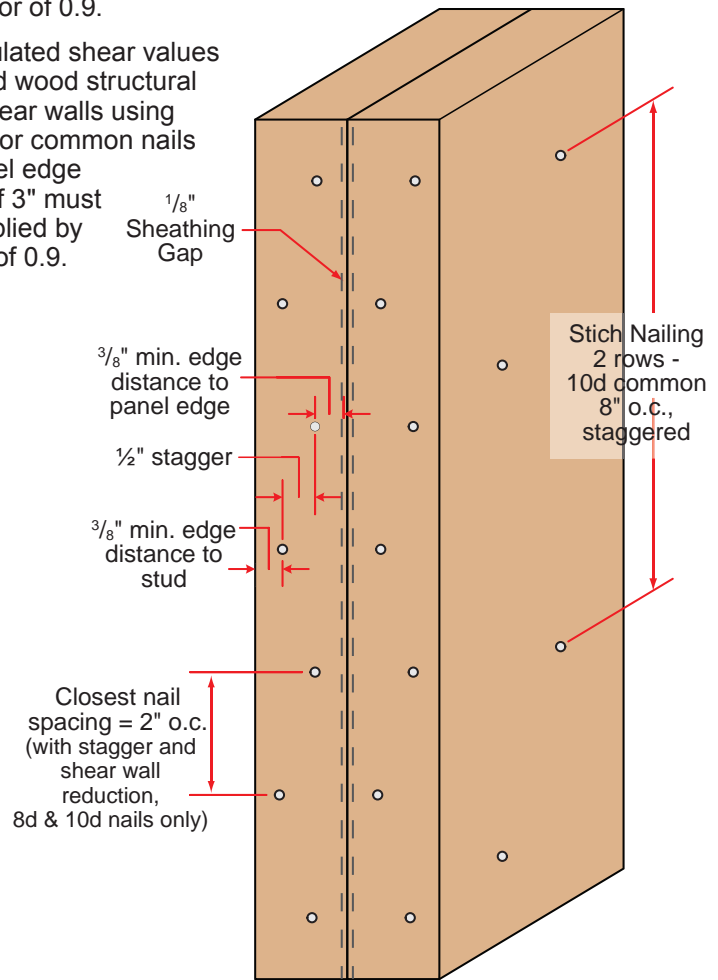

Double Stud Nailing Edges Shear Wall Only

Fire Assemblies

VERSA-STUD® are permitted as a direct replacement for solid-sawn lumber in any fire-resistance-rated wall assembly listed in Table 720.1(2) of the IBC, provided the VERSA-STUD® have a minimum depth of $\frac{5}{2}$ ".

Boise EWP is proud to introduce BC COLUMN™. BC COLUMN™ is new software that will allow customers the ability to design columns using Boise Engineered Wood Products.



Using BC COLUMN™, users can quickly:

- Design a column or stud using Boise Engineered Wood Products.
- Add gravity and out-of-plane lateral loads.
- Add bracing/supports.
- Select and test products in the design.
- Refine performance factors.
- Print design reports.

The steps are simple. To use:

- Set up the project:
- Launch BC Column.
- Enter project information.
- Specify the design and select a product.
- Describe the type of column or stud, its height and its bracing.
- Adjust the axial load and add additional out-of-plane lateral loads.
- Select a product. Specify the Deflection.
- Specify the column/stud deflection.
- Analyze and refine designs.
- Review and print design reports.

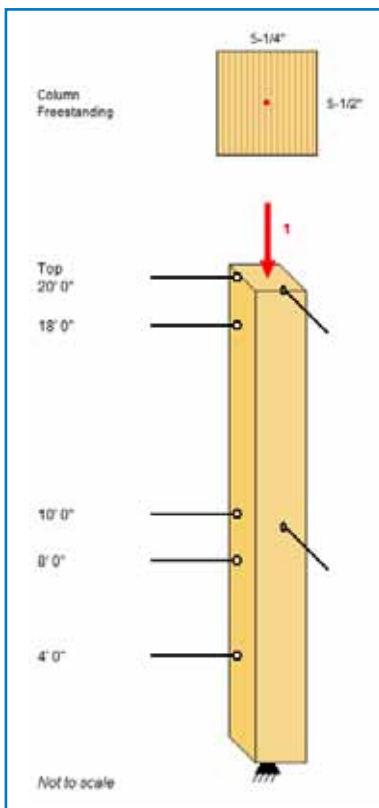
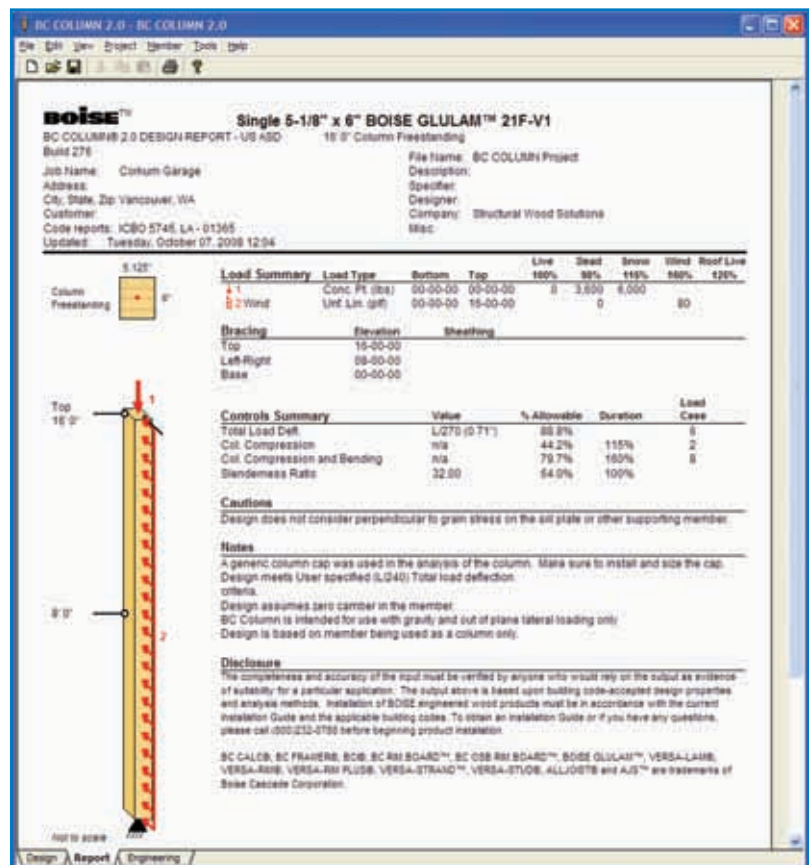
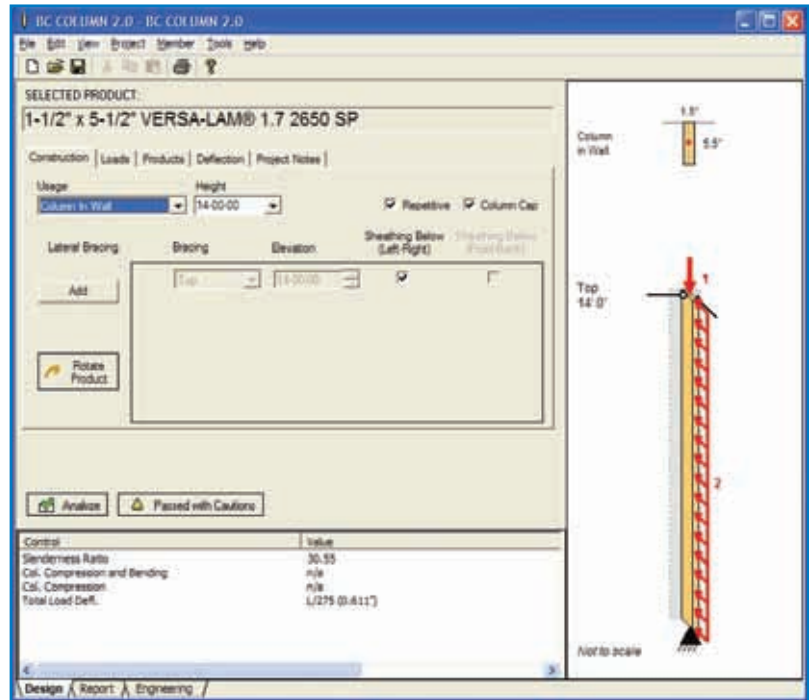

BC COLUMN is installed with BC CALC for the US market ONLY.

To request a CD or Download of BC CALC/BC COLUMN US

<http://www.bc.com/wood/ewp/software/bccalc/order/US-form.html>

BC FRAMER® CADD Framing Software

BC FRAMER® is an easy-to-use, stand-alone computer-aided drafting program with 3D capability designed to quickly create floor and roof framing layouts.

Draw walls, add framing areas, located beams and rough openings, define cross-sections and on-center spacing. In minutes, BC FRAMER® frames your layout, builds a piece and price report, creates a framing drawing with schedule, all using Boise Engineered Wood Products.

Easy-to-use editing and drawing tools allow flexibility when modifying members and adding details, symbols and accessories.

Training classes for BC FRAMER® are provided at Boise EWP's training centers located in Oregon, Louisiana, Georgia and Minnesota.

For questions, comments or a free demonstration CD visit our website at www.BC.com/ewp or email us at EWPSupport@BC.com. Information can also be obtained at 1/800-405-5969.

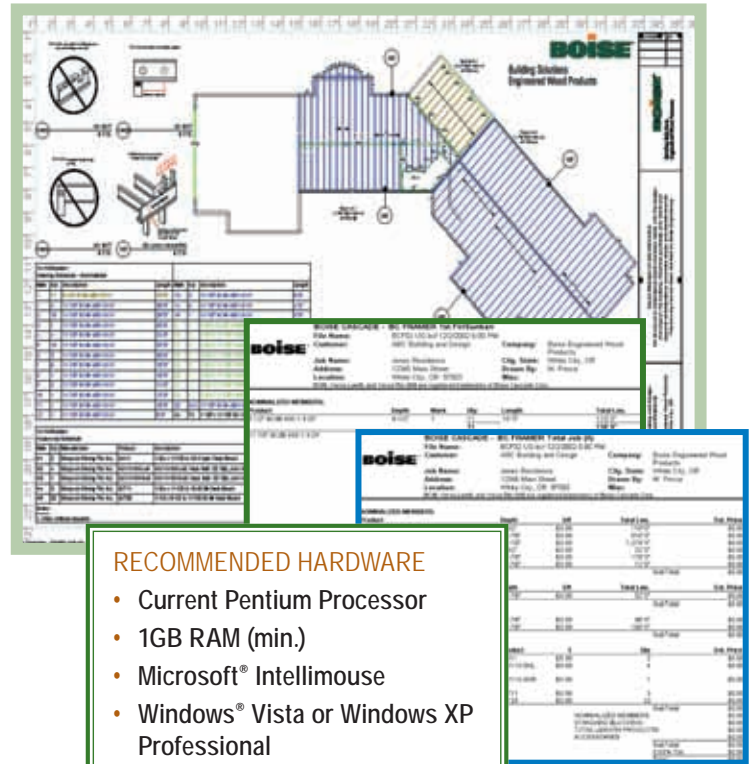

RECOMMENDED HARDWARE

- Current Pentium Processor
- 1GB RAM (min.)
- Microsoft® Intellimouse
- Windows® Vista or Windows XP Professional

Improvements in capacity or speed of these components will yield better performance.

BC CALC® Sizing Software

BC CALC® is Boise EWP's sizing software for BCI® Joists and VERSA-LAM® Beams.

BC CALC® is simple to use, yet flexible enough to analyze most joist and beam applications. Span, load and hole information entered by the user is analyzed by the program to correctly size Boise Engineered Wood Products. A comprehensive Help File menu is included in the program.

BC CALC® is available to Designers, Architects and Engineers on CD-ROM. Hardware requirements include Pentium® Processor with a recommended minimum of 512MB RAM. To order BC CALC®, call 1/800-405-5969 or email EWPSupport@BC.com.

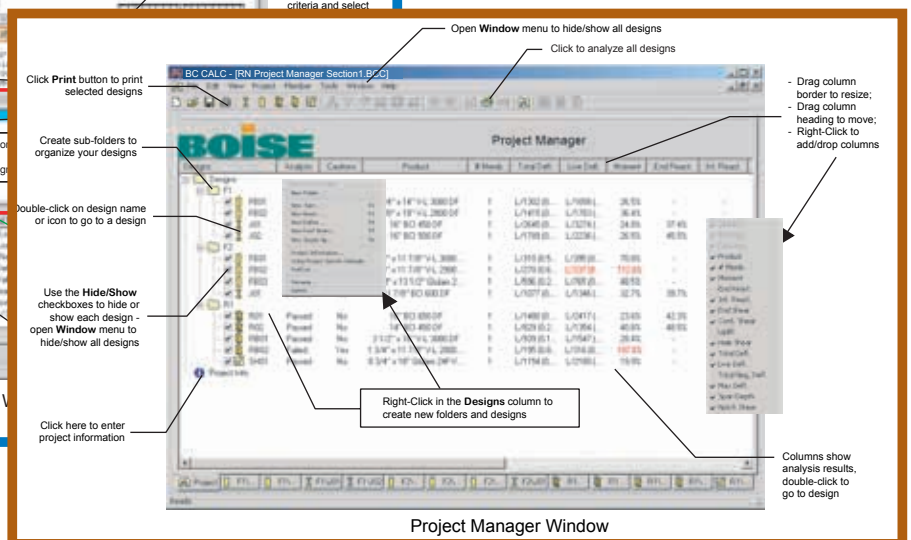
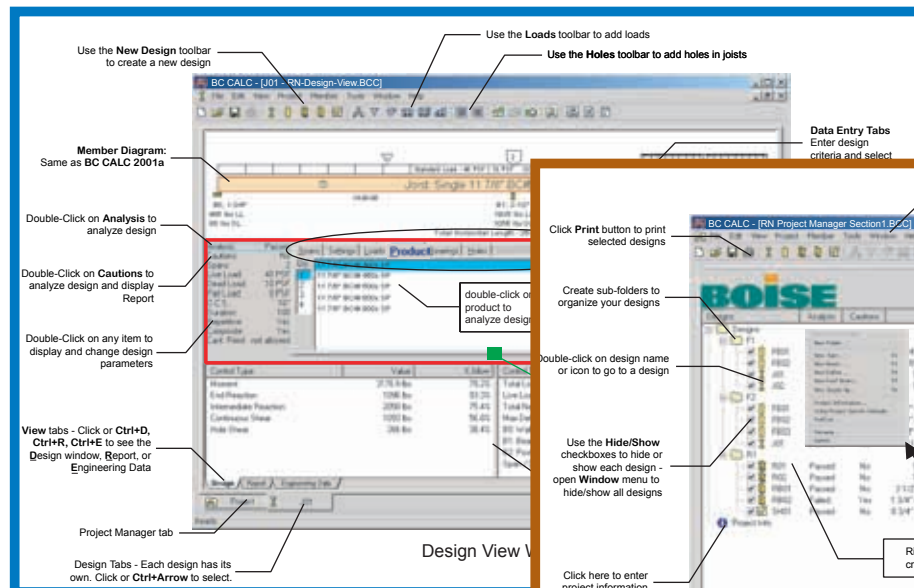

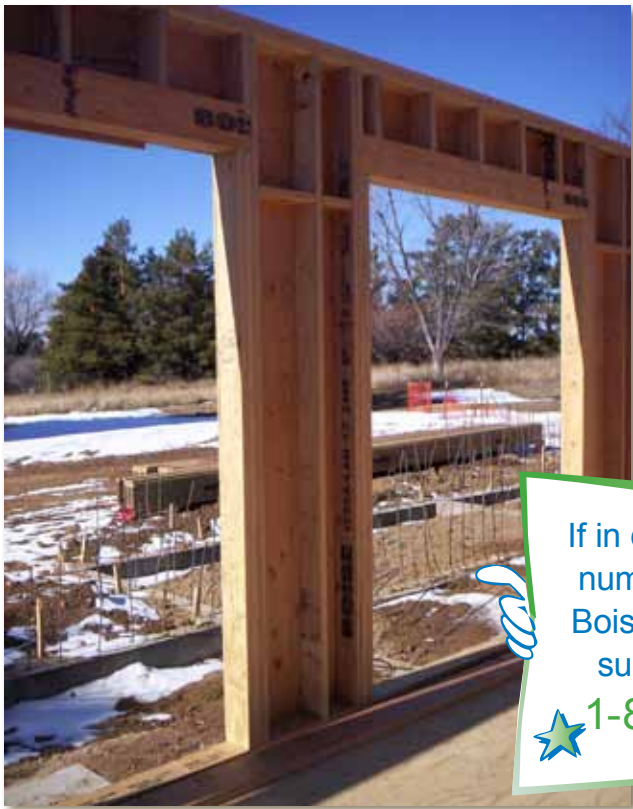

If in doubt ask! For the number of the closest Boise EWP distributor/support center, call

1-800-232-0788



Boise EWP is a participant in the Sustainable Forestry Initiative® (SFI®), a comprehensive forest management program that is a combination of environmental responsibilities and sound business practices. The procurement systems of Boise's engineered wood product facilities have been audited by PricewaterhouseCoopers to the SFI® Standard and its products will carry the SFI® Label. These procurement systems provide tracking information on Boise's supply chain sources.



Great products are only the beginning.™

Lifetime Guaranteed Quality and Performance

Boise Cascade warrants its BCI® Joist, VERSA-LAM®, and ALLJOIST® products to comply with our specifications, to be free from defects in material and workmanship, and to meet or exceed our performance specifications for the normal and expected life of the structure when correctly stored, installed and used according to our Installation Guide.

For information about Boise's engineered wood products, including sales terms and conditions, warranties and disclaimers,

visit our website at www.BC.com/ewp

BCI, BC CALC, BC FRAMER, BC RIM BOARD, BOISE CASCADE, BOISE GLULAM, SIMPLE FRAMING SYSTEM, VERSA-LAM, VERSA-RIM, VERSA-STRAND, and VERSA-STUD are trademarks of Boise Cascade, L.L.C. or its affiliates.

Your Dealer is:

If no dealer is listed, call 1-800-232-0788



Boise Cascade
Engineered Wood Products